

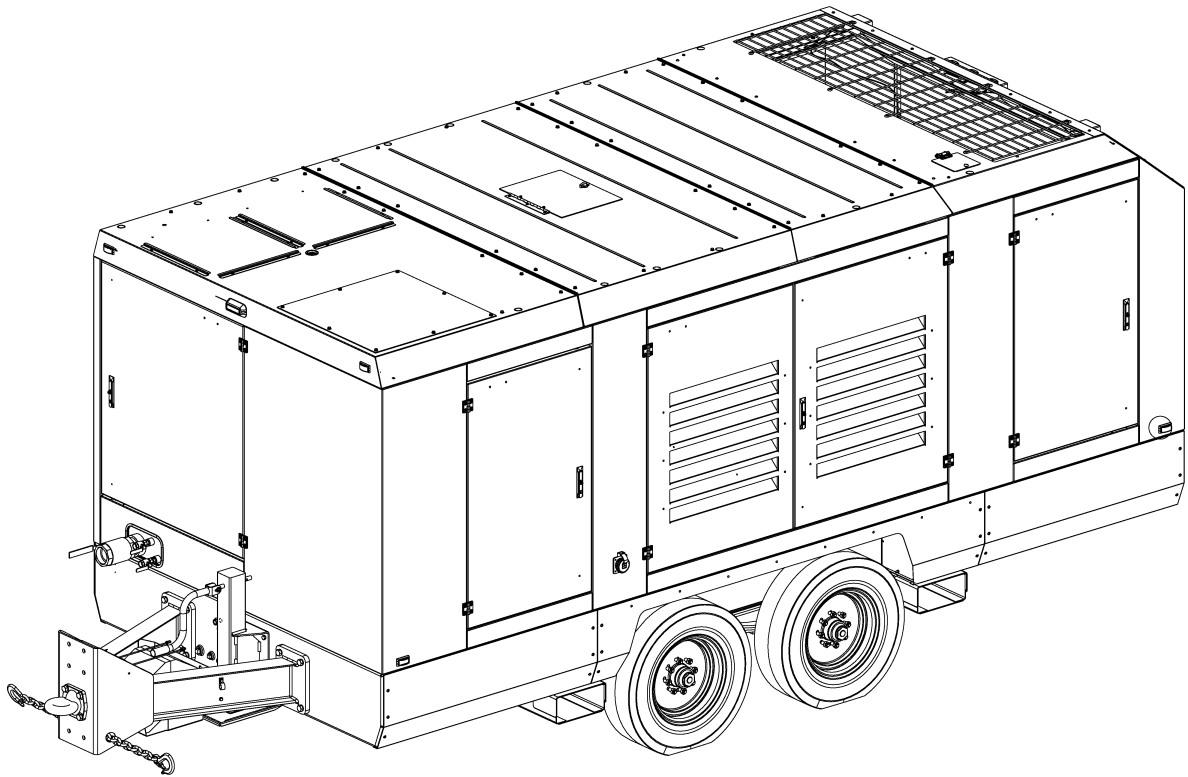

USER MANUAL

Portable Air Compressor 1600H

Tier 4 Final
Perkins



SAFETY WARNING

Users are required to read the entire User Manual before handling or using the product.

WARRANTY NOTICE

Failure to follow the instructions and procedures in this manual, or misuse of this equipment, will void its warranty.

PART NUMBER:
02250248-733 R03

The information in this manual is current as of its publication date and applies to compressor models indicated on this cover with **serial number:**

201902110000
and all subsequent serial numbers.

Publication date: **02/10/2023**
Copyright © 2023 Sullair, LLC. All rights reserved.



Service Training Courses

Sullair training courses provide hands-on and classroom instruction for the proper operation, maintenance, and servicing of Sullair products. Individual courses on Portable compressors are offered at regular intervals throughout the year at Sullair's training facility located in Michigan City, Indiana and on-site at Sullair distributor locations.

Instruction includes training on the function and installation of Sullair service parts, troubleshooting common faults and malfunctions, and actual equipment operation. These seminars are recommended for maintenance, contractor maintenance, and distributor service personnel.

For more information contact:

Sullair Training Department

1-888-SULLAIR or
219-879-5451 (ext. 5623)
training@sullair.com
www.SullairTraining.com

- Or Write -

Sullair
1 Sullair Way
Michigan City, IN 46360
Attn: Training Department



Table of Contents

Section 1: Safety	7
1.1 General.....	7
1.2 Personal protective equipment.....	7
1.3 Pressure release.....	7
1.4 Fire and explosion.....	8
1.5 Moving parts.....	9
1.6 Hot surfaces, sharp edges and sharp corners.....	10
1.7 Toxic and irritating substances.....	10
1.8 Electrical shock.....	11
1.9 Lifting.....	11
1.10 Entrapment.....	11
1.11 Implementation of lockout/tagout.....	11
1.12 Jump starting.....	12
1.13 Towing1.....	14
1.13.1 Preparing to tow.....	14
1.13.2 Towing.....	15
1.13.3 Parking or locating compressor.....	15
1.14 Fluid containment.....	16
1.15 California proposition 65.....	17
1.16 Locking device.....	17
1.17 Symbols and references.....	18
Section 2: Description	23
2.1 Introduction.....	23
2.2 Description of components.....	23
2.3 Sullair compressor unit, functional description.....	23
2.4 Cooling and lubrication system, functional description.....	25
2.5 Discharge system, functional description.....	25
2.6 Control system, functional description.....	28
2.7 Air inlet system, functional description.....	28
2.8 Engine control module, functional description.....	28
2.9 Electrical system, functional description.....	29
2.10 Wiring diagram.....	30
2.11 Piping & instrumentation, compressor system.....	34
2.12 ID, DTQ aftercooled.....	36
2.13 ID, DLQ aftercooled.....	38
2.14 Aftercooler air system, functional description.....	40
2.15 Engine exhaust aftertreatment, functional description.....	40

Section 3: Specifications	41
3.1 Specifications—1600H Tier 4 Final Perkins	41
3.2 Lubrication guide—compressor.....	43
3.3 Lubrication guide—engine.....	43
3.4 Application guide	43
Section 4: Installation	45
4.1 Locating the package	45
4.2 Ventilation and cooling	45
4.3 Service air and condensate piping	45
4.4 Remote fuel connections.....	45
Section 5: Operation	47
5.1 General.....	47
5.2 Purpose of controls	47
5.3 Startup procedure.....	48
5.4 Operation procedure	48
5.5 Shutdown procedure	49
Section 6: Controller	51
6.1 Controller layout	51
6.2 Home display.....	52
6.3 User options	54
6.4 Service options.....	55
6.4.1 Service options: Setup.....	56
6.4.2 Service options: Machine Setup	58
6.5 Help.....	59
6.5.1 Troubleshooting a non-responsive touchscreen.....	59
6.5.1.1 Resetting a non-responsive touchscreen	59
Section 7: Maintenance	61
7.1 General.....	61
7.2 Daily operation and maintenance.....	61
7.3 Engine coolant requirements.....	62
7.4 Recommended maintenance intervals	63
7.4.1 Maintenance after initial 50 hours of operation.....	63
7.4.2 Maintenance every 250 hours	63
7.4.3 Maintenance every 500 hours	63
7.4.4 Maintenance every 1500 hours	63
7.5 Engine maintenance.....	64
7.6 Parts replacement and adjustment procedures.....	64
7.6.1 Compressor fluid change procedure.....	64
7.6.2 Main fluid filter servicing	64
7.6.3 Air filter maintenance	65
7.6.3.1 Primary element removal	65

7.6.3.2 Secondary element removal..... 65

7.6.4 Control system adjustment 65

7.6.5 Separator element replacement..... 67

7.6.6 Running gear—brake shoe maintenance and adjustment..... 67

7.6.7 Brake cleaning and inspection 68

7.6.8 Brake lubrication 68

7.6.9 Bearing lubrication—grease..... 68

7.6.10 Axle bearing adjustment 69

7.7 Troubleshooting..... 70

Section 8: Noise Control.....73

8.1 Noise emissions warranty..... 73

8.2 Tampering with the noise control system is prohibited..... 73

8.3 Noise emissions maintenance and maintenance record log 74

Appendix A: Acronyms and Abbreviations77

Notes:

Section 1

Safety

NOTE



Operator is required to read entire instruction manual.

1.1 General

Sullair designs and manufactures all of its products so they can be operated safely. However, the responsibility for safe operation rests with those who use and maintain these products. The following safety precautions are offered as a guide which, if conscientiously followed, will minimize the possibility of accidents throughout the useful life of this equipment. **Read the AEM Safety Manual prior to compressor operation and towing, if applicable in your area.**

The air compressor should be operated only by those who have been trained and delegated to do so, and who have read and understood this Operator's Manual. Failure to follow the instructions, procedures and safety precautions in this manual can result in accidents and injuries.

NEVER start the air compressor unless it is safe to do so. **DO NOT** attempt to operate the air compressor with a known unsafe condition. Tag the air compressor and render it inoperative by disconnecting and locking out all power at source or otherwise disabling its prime mover so others who may not know of the unsafe condition cannot attempt to operate it until the condition is corrected.

Use and operate the air compressor only in full compliance with all pertinent OSHA requirements and/or all pertinent Federal, State and Local codes or requirements.

DO NOT modify the compressor except with written factory approval.

Each day, walk around the air compressor and inspect for leaks, loose or missing parts, damaged parts or parts out of adjustment. Perform all recommended daily maintenance.

Inspect for torn, frayed, blistered or otherwise deteriorated and degraded hoses. Replace as required.

1.2 Personal protective equipment

- A. Prior to installing or operating the compressor, owners, employers and users should become familiar with, and comply with, all applicable OSHA regulations and/or any applicable Federal, State and Local codes, standards, and regulations relative to personal protective equipment, such as eye and face protective equipment, respiratory protective equipment, equipment intended to protect the extremities, protective clothing, protective shields and barriers and electrical protective equipment, as well as noise exposure administrative and/or engineering controls and/or personal hearing protective equipment.

1.3 Pressure release

- A. Inspect the pressure relief valve at least weekly to make sure it is not blocked, closed, obstructed or otherwise disabled.
- B. To make sure the pressure relief valve is working properly, open the pressure relief valve at least once a year or more frequently as required by any applicable Federal, State and Local codes, standards and regulations.
- C. Install an appropriate flow-limiting valve between the compressor service air outlet and the shutoff (throttle) valve, when an air hose exceeding 1/2" (13 mm) inside diameter is to be connected to the shutoff (throttle) valve, to reduce pressure in case of hose failure, per OSHA Standard 29 CFR 1926.302 (b) (7) or any applicable Federal, State and Local codes, standards and regulations.
- D. When the hose is to be used to supply a manifold, install an additional appropriate flow-limiting valve between the manifold and each air hose exceeding 1/2" (13 mm) inside diameter that is to be connected to the manifold to reduce pressure in case of hose failure.

- E. Provide an appropriate flow-limiting valve for each additional 75 feet (23 m) of hose in runs of air hose exceeding 1/2" (13 mm) inside diameter to reduce pressure in case of hose failure.
- F. Flow-limiting valves are listed by pipe size and rated CFM. Select appropriate valve accordingly.
- G. **DO NOT** use tools that are rated below the maximum rating of this compressor. Select tools, air hoses, pipes, valves, filters and other fittings accordingly. **DO NOT** exceed manufacturer's rated safe operating pressures for these items.
- H. Secure all hose connections by wire, chain or other suitable retaining device to prevent tools or hose ends from being accidentally disconnected and expelled.
- I. Open fluid filler cap only when compressor is not running and is not pressurized. Shut down the compressor and bleed the sump (receiver) to zero internal pressure before removing the cap.
- J. Vent all internal pressure prior to opening any line, fitting, hose, valve, drain plug, connection or other component, such as filters and line oilers, and before attempting to refill optional air line anti-icer systems with antifreeze compound.
- K. Vent all external pressure (pressure downstream of the machine) before disconnecting any air tools, hoses, fittings, etc. or performing any maintenance procedures.
- L. Keep personnel out of line with and away from the discharge opening of hoses, tools or other points of compressed air discharge.
- M. **DO NOT** use air at pressures higher than 30 psig (2.1 bar) for cleaning purposes, and then only with effective chip guarding and personal protective equipment per OSHA Standard 29 CFR 1910.242 (b) or any applicable Federal, State and Local codes, standards and regulations.
- N. **DO NOT** engage in horseplay with air hoses as death or serious injury may result.
- O. This equipment is supplied with an ASME designed pressure vessel protected by an ASME rated relief valve. Lift the handle once a week to make sure the valve is functional. **DO NOT** lift the handle while machine is under pressure.
- P. If the machine is installed in an enclosed area it is necessary to vent the relief valve to the outside of the structure or to an area of non-exposure.
- Q. **DO NOT** remove radiator filler cap until the coolant temperature is below its boiling point. Then loosen cap slowly to its stop to relieve any excess pressure and make sure coolant is not boiling before removing cap completely. Remove radiator filler cap only when cool enough to touch with a bare hand.
- R. The ethyl ether in the replaceable cylinders used in diesel ether starting aid systems (optional) is under pressure. **DO NOT** puncture or incinerate those cylinders. **DO NOT** attempt to remove the center valve core or side pressure relief valve from these cylinders regardless of whether they are full or empty.
- S. If a manual blowdown valve is provided on the receiver, open the valve to ensure all internal pressure has been vented prior to servicing any pressurized component of the compressor air/fluid system.

1.4 Fire and explosion

WARNING

Do not attempt to operate the compressor in any classification of hazardous environment or potentially explosive atmosphere unless the compressor has been specially designed and manufactured for that duty.

- A. Refuel at a service station or from a fuel tank designed for its intended purpose. If this is not possible, ground the compressor to the dispenser prior to refueling.
- B. Clean up spills of lubricant or other combustible substances immediately, if such spills occur.
- C. Shut off air compressor and allow it to cool. Then keep sparks, flames and other sources of ignition away and **DO NOT** permit smoking in the vicinity when adding fuel, checking or adding electrolyte to batteries, checking or adding fluid, checking diesel engine ether starting aid systems, replacing cylinders, or when refilling air line anti-icer systems antifreeze compound.
- D. **DO NOT** permit fluids, including air line anti-icer system antifreeze compound or fluid film, to accumulate on, under or around acoustical material, or on any external surfaces of the air compressor. Wipe down using an aqueous industrial cleaner or steam clean as required. If necessary, remove acoustical material, clean all surfaces and then replace acoustical material. Any acoustical material with a protective covering that has been torn or punctured should be replaced immediately to prevent accumulation of liq-

- uids or fluid film within the material. **DO NOT** use flammable solvents for cleaning purposes.
- E. Disconnect and lock out all power at source prior to attempting any repairs or cleaning of the compressor or of the inside of the enclosure, if any.
 - F. Keep electrical wiring, including all terminals and pressure connectors in good condition. Replace any wiring that has cracked, cut, abraded or otherwise degraded insulation, or terminals that are worn, discolored or corroded. Keep all terminals and pressure connectors clean and tight.
 - G. Turn off battery charger before making or breaking connections to the battery.
 - H. Keep grounded and/or conductive objects such as tools away from exposed live electrical parts such as terminals to avoid arcing which might serve as a source of ignition.
 - I. Replace damaged fuel tanks or lines immediately rather than attempt to weld or otherwise repair them. **DO NOT** store or attempt to operate the compressor with any known leaks in the fuel system. Tag the compressor and render it inoperative until repair can be made.
 - J. Remove any acoustical material or other material that may be damaged by heat or that may support combustion and is in close proximity, prior to attempting weld repairs.
 - K. Keep suitable fully charged Class BC or ABC fire extinguisher or extinguishers nearby when servicing and operating the compressor.
 - L. Keep oily rags, trash, leaves, litter or other combustibles out of and away from the compressor.
 - M. Open all access doors and allow the enclosure to ventilate thoroughly prior to attempting to start the engine.
 - N. **DO NOT** operate compressor under low overhanging leaves or permit such leaves to contact hot exhaust system surfaces when operating the compressor in forested areas.
 - O. Ethyl ether used in diesel engine ether starting aid systems is extremely flammable. Change cylinders, or maintain or troubleshoot these systems only in well-ventilated areas away from heat, open flame or sparks. **DO NOT** install, store or otherwise expose ether cylinders to temperatures above 160°F (71°C). Remove ether cylinder from the compressor when operating in ambient temperatures above 60°F (16°C).
 - P. **DO NOT** attempt to use ether as a starting aid in gasoline engines or diesel engines with glow plugs as serious personnel injury or property damage may result.
 - Q. **DO NOT** spray ether into compressor air filter or into an air filter that serves both the engine and the compressor as serious damage to the compressor or personal injury may result.
 - R. Antifreeze compound used in air line anti-icer systems contains methanol which is flammable. Use systems and refill with compound only in well-ventilated areas away from heat, open flames or sparks. **DO NOT** expose any part of these systems or the antifreeze compound to temperatures above 150°F (66°C). Vapors from the antifreeze compound are heavier than air. **DO NOT** store compound or discharge treated air in confined or unventilated areas. **DO NOT** store containers of antifreeze compound in direct sunlight.
 - S. Store flammable fluids and materials away from your work area. Know where fire extinguishers are and how to use them, and for what type of fire they are intended. Check readiness of fire suppression systems and detectors if so equipped.
 - T. **DO NOT** operate the compressor without proper flow of cooling air or water or with inadequate flow of lubricant or with degraded lubricant.
 - U. **DO NOT** attempt to operate the compressor in any classification of hazardous environment unless the compressor has been specially designed and manufactured for that duty.

1.5 Moving parts

WARNING

Disconnect and lock out all power at source and verify at the compressor that all circuits are de-energized to minimize the possibility of accidental start-up, or operation, prior to attempting repairs or adjustments. This is especially important when compressors are remotely controlled.

- A. Keep hands, arms and other parts of the body and also clothing away from couplings, fans and other moving parts.
- B. **DO NOT** attempt to operate the compressor with the fan, coupling or other guards removed.

- C. Wear snug-fitting clothing and confine long hair when working around this compressor, especially when exposed to hot or moving parts.
- D. Make sure all personnel are out of and/or clear of the compressor prior to attempting to start or operate it.
- E. When adjusting the controls, it may require operation of the equipment during adjustment. **DO NOT** come in contact with any moving parts while adjusting the control regulator and setting the engine RPM. Make all other adjustments with the engine shut off. When necessary, make adjustment, other than setting control regulator and engine RPM, with the engine shut off. If necessary, start the engine and check adjustment. If adjustment is incorrect, shut engine off, readjust, then restart the engine to recheck adjustment.
- F. Keep hands, feet, floors, controls and walking surfaces clean and free of fluid, water or other liquids to minimize the possibility of slips and falls.

1.6 Hot surfaces, sharp edges and sharp corners

- A. Avoid bodily contact with hot fluid, hot coolant, hot surfaces and sharp edges and corners.
- B. Keep all parts of the body away from all points of air discharge and away from hot exhaust gases.
- C. Wear personal protective equipment including gloves and head covering when working in, on or around the compressor.
- D. Keep a first aid kit handy. Seek medical assistance promptly in case of injury. **DO NOT** ignore small cuts and burns as they may lead to infection.

1.7 Toxic and irritating substances

- A. **DO NOT** use air from this compressor for respiration (breathing) except in full compliance with OSHA

Standards 29 CFR 1920 and any other Federal, State or Local codes or regulations.

DANGER

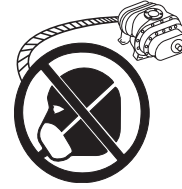

Death or serious injury can result from inhaling compressed air without using proper safety equipment. See OSHA standards and/or any applicable Federal, State, and Local codes, standards and regulations on safety equipment.

- B. **DO NOT** use air line anti-icer systems in air lines supplying respirators or other breathing air utilization equipment and **DO NOT** discharge air from these systems into unventilated or other confined areas.
- C. Operate the compressor only in open or adequately ventilated areas.
- D. Locate the compressor so that exhaust fumes are not apt to be carried towards personnel, air intakes servicing personnel areas or towards the air intake of any portable or stationary compressor.
- E. Fuels, fluids and lubricants used in this compressor are typical of the industry. Care should be taken to avoid accidental ingestion and/or skin contact. In the event of ingestion, seek medical treatment promptly. Wash with soap and water in the event of skin contact. Consult Material Safety Data Sheet for information pertaining to the specific fluid.
- F. Wear goggles or a full face shield when adding anti-freeze compound to air line anti-icer systems.
- G. Wear an acid-resistant apron and a face shield or goggles when servicing the battery. If electrolyte is spilled on skin or clothing, immediately flush with large quantities of water.
- H. Ethyl ether used in diesel engine ether starting aid systems is toxic, harmful or fatal if swallowed. Avoid contact with the skin or eyes and avoid breathing the fumes. If swallowed, **DO NOT** induce vomiting and call a physician immediately.
- I. Wear goggles or a full face shield when testing ether starting aid systems or when adding antifreeze compound to air line anti-icer systems. Keep openings of

valve or atomizer tube of ether starting aid system pointed away from yourself and other personnel.

- J. If air line anti-icer system antifreeze compound enters the eyes or if fumes irritate the eyes, they should be washed with large quantities of clean water for fifteen minutes. A physician, preferably an eye specialist, should be contacted immediately.
- K. **DO NOT** store ether cylinders or air line anti-icer system antifreeze compound in operator's cabs or in other similar confined areas.
- L. The antifreeze compound used in air line antifreeze systems contains methanol and is toxic, harmful or fatal if swallowed. Avoid contact with the skin or eyes and avoid breathing the fumes. If swallowed, induce vomiting by administering a tablespoon of salt, in each glass of clean, warm water until vomit is clear, then administer two teaspoons of baking soda in a glass of clean water. Have patient lay down and cover eyes to exclude light. Call a physician immediately.

1.8 Electrical shock

- A. Keep the towing vehicle or equipment carrier, compressor hoses, tools and all personnel at least 10 feet (3 m) from power lines and buried cables.
- B. Stay clear of the compressor during electrical storms! It can attract lightning.
- C. Keep all parts of the body and any hand-held tools or other conductive objects away from exposed live parts of electrical system. Maintain dry footing, stand on insulating surfaces and **DO NOT** contact any other portion of the compressor when making adjustments or repairs to exposed live parts of the electrical system.
- D. Attempt repairs in clean, dry and well lighted and ventilated areas only.

1.9 Lifting

- A. If the compressor is provided with a lifting bail, then lift by the bail provided. If no bail is provided, then lift by sling. Compressors to be air lifted by helicopter **must not** be supported by the lifting bail, but by slings instead. In any event, lift only in full compliance with OSHA Standards 29 CFR 1910 subpart N or any other Local, State, Military and Federal regulations that may apply.

- B. Inspect lifting bail and points of attachment for cracked welds and for cracked, bent, corroded or otherwise degraded members and for loose bolts or nuts prior to lifting.
- C. Make sure entire lifting, rigging and supporting structure has been inspected, is in good condition and has a rated capacity of at least the net weight of the compressor plus an additional 10% allowance for weight of water, snow, ice, mud, stored tools, and equipment. If you are unsure of the weight, then weigh compressor before lifting.
- D. Make sure lifting hook has a functional safety latch or equivalent, and is fully engaged and latched on the bail.
- E. Use guide ropes or equivalent to prevent twisting or swinging of the compressor once it has been lifted clear of the ground.
- F. **DO NOT** attempt to lift in high winds.
- G. Keep all personnel out from under and away from the compressor whenever it is suspended.
- H. Lift compressor no higher than necessary.
- I. Keep lift operator in constant attendance whenever compressor is suspended.
- J. Set compressor down only on a level surface capable of supporting at least its net weight plus an additional 10% allowance for the weight of water, snow, ice, mud, stored tools, and/or equipment.
- K. If the compressor is provided with parking brakes, make sure they are set, and in any event, block or chock both sides of all running wheels before disengaging the lifting hook.

1.10 Entrapment

- A. Make sure all personnel are out of compressor before closing and engaging enclosure doors.
- B. If the compressor is large enough to hold a man and if it is necessary to enter it to perform service adjustments, inform other personnel before doing so, or else secure the access door in the open position to avoid the possibility of others closing and possibly latching the door with personnel inside.

1.11 Implementation of lockout/tagout

The energy control procedure defines actions necessary to lockout a power source of any machine to be repaired, serviced or set-up, where unexpected motion, or an elec-

trical or other energy source, would cause personal injury or equipment damage. The power source on any machine shall be locked out by each employee doing the work except when motion is necessary during setup, adjustment or trouble-shooting.

A. The established procedures for the application of energy control shall cover the following elements and actions and shall be initiated only by Authorized Persons and done in the following sequence:

1. Review the equipment or machine to be locked and tagged out.
2. Alert operator and supervisor of which machine is to be worked on, and that power and utilities will be turned off.
3. Check to make certain no one is operating the machine before turning off the power.
4. Turn off the equipment using normal shutdown procedure.
5. Disconnect the energy sources:
 - a. Air and hydraulic lines should be bled, drained and cleaned out. There should be no pressure in these lines or in the reservoir tanks. Lockout or tag lines or valves.
 - b. Any mechanism under tension or pressure, such as springs, should be released and locked out or tagged.
 - c. Block any load or machine part prior to working under it.
 - d. Electrical circuits should be checked with calibrated electrical testing equipment and stored energy and electrical capacitors should be safely discharged.
6. Lockout and/or Tagout each energy source using the proper energy isolating devices and tags. Place lockout hasp and padlock or tag at the point of power disconnect where lockout is required by each person performing work. Each person shall be provided with their own padlock and have possession of the only key. If more than one person is working on a machine *each* person *shall* affix personal lock and tag using a multi-lock device.
7. Tagout devices shall be used only when power sources are not capable of being locked out by use of padlocks and lockout hasp devices. The name of the person affixing tag to power source must be on tag along with date tag was placed on power source.

8. Release stored energy and bring the equipment to a “zero mechanical state”.
9. Verify Isolation: Before work is started, test equipment to ensure power is disconnected.

B. General Security

1. The lock shall be removed by the “Authorized” person who put the lock on the energy-isolating device. No one other than the person/persons placing padlocks and lockout hasps on power shall remove padlock and lockout hasps and restore power. However, when the authorized person who applied the lock is unavailable to remove it his/her Supervisor may remove padlock/padlocks and lockout hasps and restore power only if it is first:
 - a. verified that no person will be exposed to danger.
 - b. verified that the “Authorized” person who applied the device is not in the facility.
 - c. noted that all reasonable efforts to contact the “Authorized” person have been made to inform him or her that the lockout or tagout device has been removed.
 - d. ensured that the “Authorized” person is notified of lock removal before returning to work.
2. Tagout System—Tags are warning devices affixed at points of power disconnect and are not to be removed by anyone other than the person placing tag on power lockout. Tags shall never be by-passed, ignored, or otherwise defeated.

1.12 Jump starting

- A. Observe all safety precautions mentioned elsewhere in this manual.
- B. Batteries may contain hydrogen gas which is flammable and explosive. Keep flames, sparks and other sources of ignition away.
- C. Batteries contain acid which is corrosive and poisonous. **DO NOT** allow battery acid to contact eyes, skin, fabrics or painted surfaces as serious personal injury or property damage could result. Flush any contacted areas thoroughly with water immediately. Always wear an acid-resistant apron and face shield when attempting to jump start the compressor.

- D. Remove all vent caps (if so equipped) from the battery or batteries in the compressor. **DO NOT** permit dirt or foreign matter to enter the open cells.
- E. Check fluid level. If low, bring fluid to proper level before attempting to jump start (not applicable to maintenance-free batteries).
- F. **DO NOT** attempt to jump start if fluid is frozen or slushy. Bring batteries up to at least 60°F (16°C) before attempting to jump start or it may explode.
- G. Cover open cells of all compressor batteries with clean dampened cloths before attempting to jump start.
- H. Attempt to jump start only with a vehicle having a negative ground electrical system with the same voltage, and is also equipped with a battery or batteries of comparable size or larger than supplied in the compressor. **DO NOT** attempt to jump start using motor generator sets, welders or other sources of DC power as serious damage may result.
- I. Bring the starting vehicle alongside the compressor, but **DO NOT** permit metal to metal contact between the compressor and the starting vehicle.
- J. Set the parking brakes of both the compressor (if provided) and the starting vehicle or otherwise block both sides of all wheels.
- K. Place the starting vehicle in neutral or park, turn off all non-essential accessory electrical loads and start its engine.
- L. Use only jumper cables that are clean, in good condition and are heavy enough to handle the starting current.
- M. Avoid accidental contact between jumper cable terminal clips or clamps and any metallic portion of either the compressor or the starting vehicle to minimize the possibility of uncontrolled arcing which might serve as a source of ignition.
- N. Positive battery terminals are usually identified by a plus (+) sign on the terminal and the letters POS adjacent to the terminal. Negative battery terminals are usually identified by the letters NEG adjacent to the terminal or a negative (-) sign.
- O. Connect one end of a jumper cable to the positive (POS) (+) battery terminal in the starting vehicle. When jump starting 24V compressors and if the starting vehicle is provided with two (2) 12V batteries connected in series, connect the jumper cable to the positive (POS) (+) terminal of the ungrounded battery.
- P. Connect the other end of the same jumper cable to the positive (POS) (+) terminal of the starter motor battery in the compressor when jump starting 24V compressors, to the positive (POS) (+) terminal of the ungrounded battery in the compressor.
- Q. Connect one end of the other jumper cable to the grounded negative (NEG) (-) terminal of the battery in the starting vehicle. When jump starting 24V compressors and if the starting vehicle is provided with two (2) 12V batteries connected in series, connect the jumper cable to the negative (NEG) (-) terminal of the grounded battery.
- R. Check your connections. **DO NOT** attempt to start a 24V compressor with one 12V battery in the starting vehicle. **DO NOT** apply 24V to one 12V battery in the compressor.
- S. Connect the other end of this same jumper cable to a clean portion of the compressor engine block away from fuel lines, the crank case breather opening and the battery.
- T. Start the compressor in accordance with normal procedure. Avoid prolonged cranking.
- U. Allow the compressor to warm up. When the compressor is warm and operating smoothly at normal idle RPM, disconnect the jumper cable from the engine block in the compressor, then disconnect the other end of this same cable from the grounded negative (NEG) (-) terminal of the battery in the starting vehicle. Then disconnect the other jumper cable from the positive (POS) (+) terminal of the battery in the compressor, or if provided with two (2) 12V batteries connected in series, from the ungrounded battery in the compressor, and finally, disconnect the other end of this same jumper cable from the positive (POS) (+) terminal of the battery in the starting vehicle or from the positive (POS) (+) terminal of the ungrounded battery in the starting vehicle, if it is provided with two (2) 12V batteries connected in series.
- V. Remove and carefully dispose of the dampened cloths, as they may now be contaminated with acid, then replace all vent caps.

1.13 Towing¹

1.13.1 Preparing to tow

WARNING

Do **NOT** tow the compressor should its weight exceed the rated limit of the tow vehicle, as the vehicle may not brake safely with excess weight. See rated limit in tow vehicle Operator's Manual, and review its instructions and other requirements for safe towing.

- A. Prior to hitching the air compressor to the tow vehicle, inspect all attachment parts and equipment, checking for (I) signs of excessive wear or corrosion, (II) parts that are cracked, bent, dented or otherwise deformed or degraded, and (III) loose nuts, bolts or other fasteners. Should any such condition be present, **DO NOT TOW** until the problem is corrected.
- B. Back the tow vehicle to the compressor and position it in preparation for coupling the compressor.
- C. If the compressor is provided with a drawbar latched in the vertical upright position, carefully unlatch drawbar and lower it to engage the coupling device. If not, raise drawbar with the jack to engage coupling device or otherwise couple the compressor to the towing vehicle.

WARNING

This equipment may be tongue heavy. **DO NOT** attempt to raise or lower the drawbar by hand if the weight is more than you can safely handle.

Use the screw jack provided or a chain fall if you cannot lift or lower it without avoiding injury to yourself or others. Keep hands and fingers clear of the coupling device and all other pinch points. Keep feet clear of drawbar to avoid injury in case it should slip from your hands.

- D. Make sure the coupling device is fully engaged, closed and locked.
- E. If chains are provided, pass each chain through its point of attachment on the towing vehicle; then hook each chain to itself by passing the grab hook over (not through) a link. Cross chains under the front of drawbar before passing them through points of

attachment on towing vehicle to support the front of drawbar in case it should accidentally become uncoupled.

- F. Make sure that the coupling device and adjacent structures on the towing vehicle (and also, if utilized, chain adjustment, brake and/or electrical interconnections) **DO NOT** interfere with or restrict motion of any part of the compressor, including its coupling device, with respect to the towing vehicle when maneuvering over any anticipated terrain.
- G. If provided, make sure chain length, brake and electrical interconnections provide sufficient slack to prevent strain when cornering and maneuvering, yet are supported so they cannot drag or rub on road, terrain or towing vehicle surfaces which might cause wear that could render them inoperative.

WARNING

This equipment may be tongue heavy. **DO NOT** attempt to raise or lower the drawbar by hand if the weight is more than you can safely handle.

CAUTION

Retract the front screw jack only after attaching the compressor to the tow vehicle. Raise the screw jack to its full up position and pull the pin connecting the jack to the drawbar. Rotate the screw jack to its stowed position, parallel to the drawbar, and reinsert the pin. Make sure the jack is secured in place prior to towing.

If a caster wheel is provided on the screw jack it is part of the screw jack and can not be removed. Follow the same procedure for stowing away the wheeled jack as you would for the standard screw jack. Pull the pin connecting the jack to the drawbar and raise the screw jack to its full up position. Rotate the screw jack to its stowed position, parallel to the drawbar, and reinsert the pin. Make sure the jack is secured in place prior to towing.

- H. On two-wheeled models, fully retract front screw jack and any rear stabilizer legs. If a caster wheel is provided on the screw jack it is part of the screw jack, and can not be removed. Follow the same procedure for stowing away the wheeled jack as you would for

¹ While not towed in the usual sense of the word, many of these instructions are directly applicable to skid-mounted portable air compressors as well.

the standard screw jack. Pull the pin connecting the jack to the drawbar and raise the screw jack to its full upright position. Rotate the screw jack to its stowed position, parallel to the drawbar, and reinsert the pin. Make sure the jack is secured in place prior to towing.

- I. Make sure tires are in good condition and are the size (load range) specified and are inflated to the specified pressures. **DO NOT** change the tire size or type. Also, make sure wheel bolts, lugs or nuts are tightened to the specified torques.
- J. If provided, make sure all dual stop, tail directional and clearance lights are operating properly and that their lenses are clean and functional. Also, make sure all reflectors and reflecting surfaces, including the slow moving vehicle emblem on compressors provided with same, are clean and functional.
- K. Make sure all service air hoses (not air brake hoses) are disconnected or are fully stowed and secured on hose reels, if provided.
- L. Make sure all access doors and tool box covers are closed and latched. If the compressor is large enough to hold a man, make sure all personnel are out before closing and latching access doors.
- M. Make sure parking brakes in towing vehicle are set, or that its wheels are chocked or blocked, or that it is otherwise restrained from moving. Then, release the compressor parking brakes, if provided.
- N. Make sure the compressor wheels are not chocked or blocked, and that all tie-downs, if any, are free.
- O. Test running brake operation, including breakaway switch operation if provided, before attempting to tow the compressor at its rated speed or less when conditions prevail.
- P. **DO NOT** carry loose or inappropriate tools, equipment or supplies on or in the compressor.
- Q. **DO NOT** load this equipment with accessories or tools such that it is unbalanced from side to side or front to back. Such unbalance will reduce the towability of this equipment and may increase the possibility of tipping, rolling over, jackknifing, etc. Loss of control of the towing vehicle may result.

1.13.2 Towing

- A. Observe all Federal, State, and Local laws while towing this equipment (including those specifying minimum speed).

- B. **DO NOT** exceed the towing speeds listed below under ideal conditions. Reduce your speed according to posted speed limits, weather, traffic, road or terrain conditions:
 - C. Two axle four-wheel or three axle six-wheel steerable models: 15 mph (24 km/h).
 - D. All other models: 55 mph (88 km/h).
- E. Remember that the portable air compressor may approach or exceed the weight of the towing vehicle. Maintain increased stopping distances accordingly. **DO NOT** make sudden lane changes, **U-turns** or other maneuvers. Such maneuvers can cause the compressor to tip, roll over, jackknife or slide and cause loss of control of the towing vehicle. Tipping, rolling over, etc. can occur suddenly without warning. **U-turns** especially should be made slowly and carefully.
- F. Avoid grades in excess of 15° (27%).
- G. Avoid potholes, rocks and other obstructions, and soft shoulders or unstable terrain.
- H. Maneuver in a manner that will not exceed the freedom of motion of the compressor's drawbar and/ or coupling device, in or on the towing vehicle's coupling device and/or adjacent structure whether towing forward or backing up, regardless of the terrain being traversed.
- I. **DO NOT** permit personnel to ride in or on the compressor.
- J. Make sure the area behind, in front of, and under the compressor is clear of all personnel and obstructions prior to towing in any direction.
- K. **DO NOT** permit personnel to stand or ride on the drawbar, or to stand or walk between the compressor and the towing vehicle.

1.13.3 Parking or locating compressor

- A. Park or locate compressor on a level surface, if possible. If not, park or locate compressor across grade so the compressor does not tend to roll downhill. **DO NOT** park or locate compressor on grades exceeding 15° (27%) using wheel chocks or 10° (17.5%) using only the on-board manual parking brakes.
- B. Make sure compressor is parked or located on a firm surface that can support its weight.
- C. Park or locate compressor so the wind, if any, tends to carry the exhaust fumes and radiator heat away from the compressor air inlet openings, and also

where the compressor will not be exposed to excessive dust from the work site.

- D. On steerable models, park compressor with front wheels in straight-ahead position.
- E. Set parking brakes and disconnect breakaway switch cable and all other interconnecting electrical and/or brake connections, if provided.
- F. Block or chock both sides of all wheels.
- G. If provided, unhook chains and remove them from the points of chain attachment on the towing vehicle, then hook chains to bail on drawbar or wrap chains around the drawbar and hook them to themselves to keep chains off the ground which might accelerate rusting.
- H. If outfitted, lower front screw jack and/or any front and rear stabilizer legs. Make sure the surface they contact has sufficient load bearing capability to support the weight of the compressor.

WARNING

This equipment may be tongue heavy. **DO NOT** attempt to raise or lower the drawbar by hand if the weight is more than you can safely handle.

CAUTION

Retract the front screw jack only after attaching the compressor to the tow vehicle. Raise the screw jack to its full up position and pull the pin connecting the jack to the drawbar. Rotate the screw jack to its stowed position, parallel to the drawbar, and reinsert the pin. Make sure the jack is secured in place prior to towing.

On two-wheeled models, fully retract front screw jack and any rear stabilizer legs. If a caster wheel is provided on the screw jack it is part of the screw jack and can not be removed. Follow the same procedure for stowing away the wheeled jack as you would for the standard screw jack. Pull the pin connecting the jack to the drawbar and raise the screw jack to its full up position. Rotate the screw jack to its stowed position, parallel to the drawbar, and reinsert the pin. Make sure the jack is secured in place prior to towing.

- I. If a caster wheel is provided on the screw jack, it is part of the screw jack and cannot be removed. Follow the same procedure for stowing away the wheeled jack as you would for the standard screw jack. Raise the screw jack to its full upright position and pull the pin connecting the jack to the drawbar. Rotate the screw jack to its stowed position, parallel to the drawbar and reinsert the pin. Make sure the jack is secured in place prior to towing.
- J. Disconnect coupling device, keeping hands and fingers clear of all pinch points. If the compressor is provided with a drawbar, **DO NOT** attempt to lift the drawbar or if hinged, to raise it to the upright position by hand, if the weight is more than you can safely handle. Use a screwjack or chain fall if you cannot lift or raise the drawbar without avoiding injury to yourself or others.
- K. Move the towing vehicle well clear of the parked compressor and erect hazard indicators, barricades and/or flares (if at night) if compressor is parked on or adjacent to public roads. Park so as not to interfere with traffic.

NOTE

While not towed in the usual sense of the word, many of these instructions are directly applicable to skidmounted portable air compressors as well.

1.14 Fluid containment

The compressor may be equipped with a containment frame that contains spillage of internal fluids such as fuel, engine oil, coolant, and compressor oil. All fluids captured in the fluid spill containment should be immediately cleaned up and properly disposed of.

The canopy is designed to minimize water ingress. However, some amount of rain water will collect in the containment frame, if equipped, and could mix with residual spilled fluids. This containment fluid should be cleaned out periodically so that it does not overflow the containment level and spill out on the ground, especially prior to moving the compressor. Drain plugs are provided in the frame for removal of containment fluid. Depending on the drain locations within the frame, the jack stand may need to be

raised and lowered to encourage flow of liquid to the various drains.

NOTE

Never pour any hazardous substance down any drain or sewer. Dispose of fluids in accordance with applicable federal, state and local regulations.

1.15 California proposition 65**WARNING**

Breathing diesel engine exhaust exposes you to chemicals known to the State of California to cause cancer and birth defects or other reproductive harm.

- Always start and operate the engine in a well-ventilated area.
- If in an enclosed area, vent the exhaust to the outside.
- Do not modify or tamper with the exhaust system.
- Do not idle the engine except as necessary.





























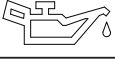



For more information go to www.P65warnings.ca.gov/diesel

1.16 Locking device**IMPORTANT**

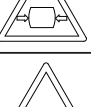





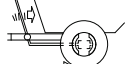



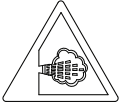









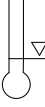
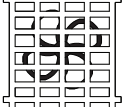

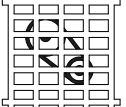

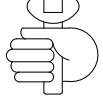



Secure the compressor's canopy with a padlock or other locking mechanism to prevent injury and unauthorized access to the interior of the compressor.

1.17 Symbols and references



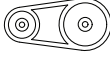
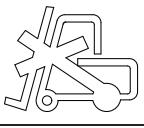

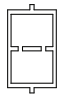







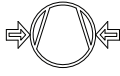





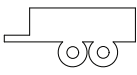

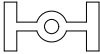







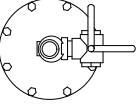
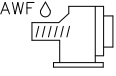

The symbols below may or may not be used. Please refer to the decals set forth on the machine for applicable symbols.

	DIESEL FUEL		HEARING PROTECTION
	ROTARY COMPRESSOR		HARD HAT
	TEST RUN		SAFETY GLASSES
	DRAIN		HOOK HERE
	HIGH PRESSURE		DO NOT REMOVE MANUAL
	SHUT-OFF VALVE W/ SAFETY		DO NOT BREATHE COMPRESSED AIR
	NO		DO NOT STAND ON SERV. VALVE
	ENGINE		DO NOT OPERATE W/ DOORS OPEN
	COMPRESSOR		DO NOT OPEN
	ENGINE OIL		DO NOT STACK
	ENGINE COOLANT		ELECTRICAL SHOCK
	WATER		AIR FLOW
	OIL		HOT SURFACE
	DO NOT ABNORMAL SHUTDOWN		PRESSURIZED VESSEL
	CLOSED MECHANICAL		PRESSURIZED COMPONENT
	FUSE		
	LOW PRESSURE		
	READ MANUAL		
	BRAKES		

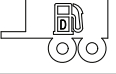

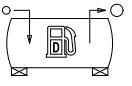









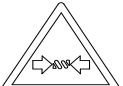

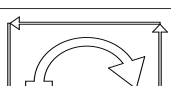

SAFETY SYMBOLS 1

	DANGEROUS OUTLET		ENGINE START
	REMOTELY CONTROLLED		ENGINE ECM
	CORROSIVE		READ/WRITE DATA
	WARNING		INTAKE AIR
	DO NOT MAINTENANCE		EXHAUST GAS
	BELOW TEMPERATURE		FAN GUARD
	DO NOT TOW		BELT GUARD
	BAR/PSI		SERVICE POINT
	BATTERY		LOW TEMPERATURE
	BATTERY DISCONNECT		STD AIR
	OFF		A/C AIR
	ON		24 HOURS
	RESET		BELTS
	NO FORKLIFT		FILTER
	FORK LIFT HERE		STRAINER
	DIRECTION OF ROTATION		

SAFETY SYMBOLS 2

	RADIATOR		HOUR METER
	AIR-CIRCULATING FAN		COMPRESSOR AIR PRESSURE
	AIR-COOLED OIL COOLER		START
	LIQUID-COOLED OIL COOLER		CONTROL
	LUBRICATION		ENGINE PREHEAT LOW TEMP AID
	TRAILER TOWING MODE		ENGINE WARNING
	AXLE		FUEL LEVEL
	LUBRICANT GREASE		ENGINE RPM n/min
	EXAMINE, CHECK		ENGINE OIL PRESSURE
	CRUSH/PINCH POINT		ENGINE COOLANT TEMPERATURE
	FUNCTIONAL ARROW		COMPRESSOR TEMPERATURE
	ENGINE INTAKE AIR FILTER		DO NOT MIX COOLANTS
	PRESSURE CONTROL		AFTERCOOLER BYPASS VALVE
	INLET VALVE SPRING AWF		DRAIN HEATER
	INTERNAL FUEL		BATTERY HEATER
	EXTERNAL FUEL		COMPRESSOR OIL HEAT
	SIDE DOOR T-LATCH		STACKING LIMIT BY NUMBER

SAFETY SYMBOLS 3

	DO NOT OPERATE WHILE STACKED		WATER DRAIN
	PRESSURIZED SPRING		SEVER (FAN)
	DO NOT MIX FLUIDS		DEF FLUID ONLY
	AUTO START/STOP		RUN
	FLUID DRAIN		LOW FUEL
	DPF: DIESEL PARTICULATE FILTER		HEST: HIGH EMISSIONS SYSTEM TEMPERATURE
	DPF REGEN. INHIBIT		EMISSIONS MALFUNCTION INDICATION
	ENGINE NOT ALLOWED TO CRANK ----- AIR SHUTOFF ACTIVE		ENGINE STOP
	CONTROLLER AUTO MODE		

SAFETY SYMBOLS 4

Notes:

Section 2

Description

2.1 Introduction

Sullair portable air compressor models offer superior performance and reliability while requiring only minimal maintenance.

The compressor is equipped with a Sullair rotary screw compressor unit. Compared to other compressors, Sullair's compressor is unique in mechanical reliability and compressor durability. No inspection is required of the working parts within the compressor unit.

As you continue reading this manual and come to learn how the compressor operates and is cared for, you will see how surprisingly easy it is to keep a Sullair compressor in top operating condition.

Read *Section 7: Maintenance* to keep your compressor in top operating condition. Should any problem or question arise which cannot be answered in this manual, contact your nearest Sullair representative or the Sullair Service Department.

2.2 Description of components

Refer to *Figure 2-1* on page 24. The components and assemblies of the Sullair portable air compressor models are clearly shown. The package includes a compressor, diesel engine, engine exhaust aftertreatment, compressor inlet system, compressor cooling and lubrication system, compressor discharge system, capacity control system, instrument panel and electrical system. The machine is also supplied with sound deadening insulation to lower noise emissions to meet EPA and/or any Federal, State, or Local noise requirement. The Sullair compressor unit is driven by an industrial engine designed to provide enough horsepower for more than adequate reserve at rated conditions. Refer to the *Engine Operator's Manual* for a more detailed description of the engine.

The engine cooling system is comprised of a radiator, high capacity fan and thermostat. The high capacity fan pushes air through the radiator, keeping the engine at the proper operating temperature.

The same fan also cools the fluid in the compressor cooling and lubrication system through the compressor fluid

cooler (which is mounted adjacent to the radiator). As air passes through the cooler, the heat of compression is removed from the fluid.

The same fan also cools the engine intake air supply (which is mounted adjacent to the fluid cooler). As air passes through the air to air aftercooler heat is removed which was introduced by the engine's turbo charger. The engine is coupled to the compressor unit with a non-lubricated, vulcanized rubber disk and a drive flange-type coupling.

2.3 Sullair compressor unit, functional description

Sullair compressors feature the Sullair compressor unit, a single-stage, positive displacement, flood lubricated-type compressor. This unit provides continuous compression to meet your needs.

NOTE

With a Sullair compressor, there is no maintenance or inspection of the internal parts of the compressor unit permitted in accordance with the terms of the warranty.

Sullair compressors are factory-filled with Sullair AWF[®] lubricant. For more information on fluid fill, refer to *Section 3: Specifications*.

Fluid is injected into the compressor unit and mixes directly with the air as the rotors turn, compressing the air. The fluid flow has three basic functions:

- As coolant, it controls the rise of air temperature normally associated with the heat of compression.
- Seals the clearance paths between the rotors and the stator and also between the rotors themselves.
- Acts as a lubricating film between the rotors allowing one rotor to directly drive the other, which is an idler.

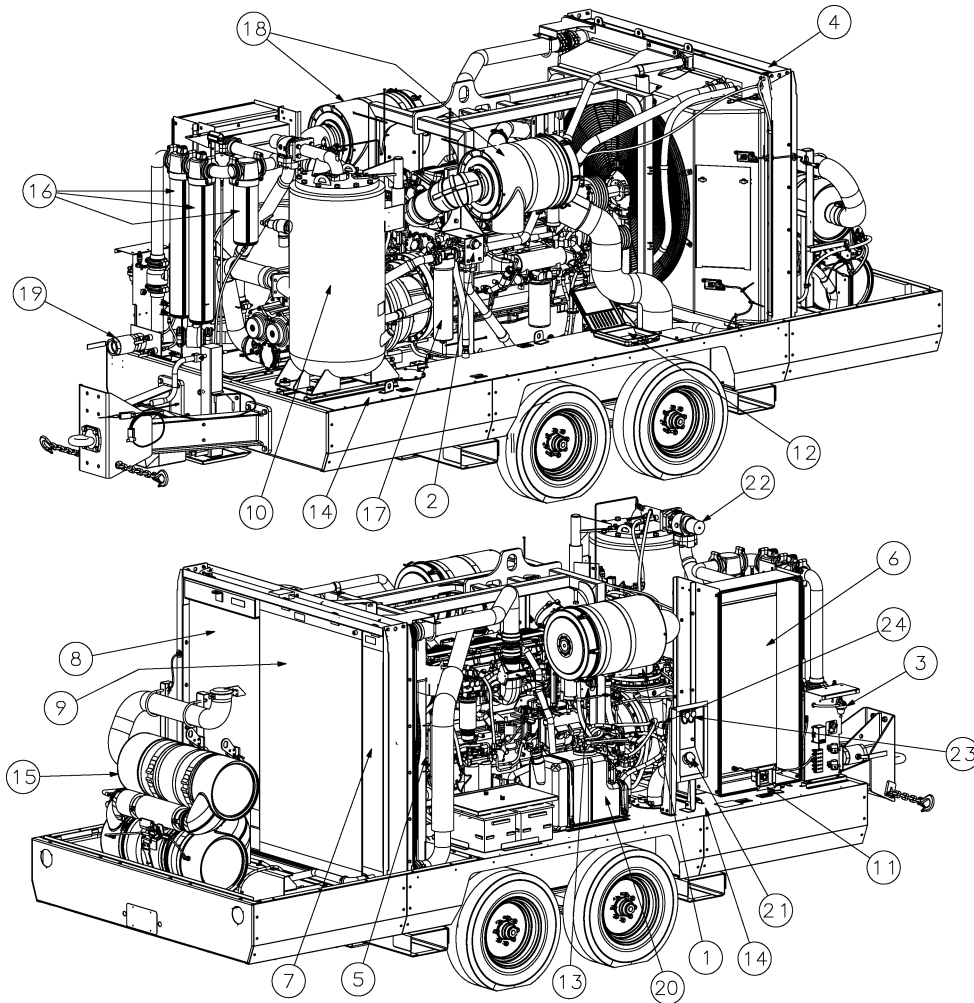

- | | |
|-----------------------------------|--|
| 1. Compressor inlet valve | 13. Battery disconnect switch |
| 2. Compressor fluid thermal valve | 14. Fuel tanks |
| 3. Pressure regulator valve | 15. Engine CEM module |
| 4. Engine coolant fill | 16. Discharge air water separator and filters [†] |
| 5. Fuel cooler | 17. Compressor fluid filter |
| 6. Aftercooler [†] | 18. Engine & compressor air intake filters |
| 7. Engine charge air cooler | 19. Discharge air service valves |
| 8. Engine radiator | 20. Diesel exhaust fluid (DEF) tank |
| 9. Compressor fluid cooler | 21. Fuel fill |
| 10. Receiver tank | 22. Minimum pressure check valve |
| 11. E-stop button | 23. External fuel connections |
| 12. Manual box | 24. Fuel selection valve |

[†]If equipped.

Figure 2-1: Main components of 1600H Tier 4 Final compressors

After the air/fluid mixture is discharged from the compressor unit, the fluid is separated from the air. At this time, the air flows through a separator and an aftercooler (if provided) then to the service line while the fluid is being cooled in preparation for reinjection.

2.4 Cooling and lubrication system, functional description

Refer to *Figure 2-2* on page 26. The compressor cooling and lubrication system is designed to provide adequate lubrication as well as maintain the proper operating temperature of the compressor. In addition to the cooler and fan, the system consists of a main filter and thermal valve.

Fluid is used in the system as a coolant and a lubricant. The fluid is housed in the receiver tank.

Upon start-up, the fluid temperature is cool, and routing to the cooler is not required. The fluid first enters the thermal valve and then flows on to the compressor unit, bypassing the cooler. As the compressor continues to operate, the temperature of the fluid rises and the thermal valve element begins to shift. This forces a portion of the fluid to the fluid cooler. The cooler is a radiator-type that works in conjunction with the engine fan. The fan pushes air through the cooler removing the heat of compression from the fluid. From the cooler, the fluid is routed back to the thermal valve.

Before the temperature of the fluid reaches the valve set point, cooled fluid is mixed with warmer fluid. When the temperature of the fluid reaches 190°F (86.1°C), the thermal element shifts completely causing all fluid to flow to the cooler. The thermal valve incorporates a pressure relief valve, which allows fluid to bypass the cooler, if the cooler becomes plugged or frozen. This helps assure that fluid will continue to be provided to the compressor for lubrication. After the fluid passes through the thermal valve it is then directed through the main fluid filter. There, the fluid is filtered in preparation for injection into the compression chamber and bearings of the compressor unit. The filter has a replaceable element and a built-in bypass valve which allows the fluid to flow even when the filter element becomes plugged and requires changing or when the viscosity of the fluid is too high for adequate flow. The filter housing includes a pressure differential gage to monitor the cleanliness of the compressor oil filter. Please refer to *Section 7.6.2: Main fluid filter servicing* on page 64 for further details. After the fluid is properly filtered, it then flows on to the compressor unit where it lubricates, seals and cools the compression chamber as well as lubricates the bearings and gears.

The fluid stop valve functions on shutdown when it shuts off the fluid supply to the compressor unit. The fluid stop valve is held open by a pressure signal from the compressor discharge. At shutdown, the pressure signal is lost and the fluid stop valve closes, isolating the compressor unit from the cooling system. This prevents oil from pooling into the compressor unit.

2.5 Discharge system, functional description

Refer to *Figure 2-3* on page 27. The Sullair compressor unit discharges compressed air/fluid mixture into the receiver tank.

The receiver tank has three functions:

- It acts as a primary fluid separator.
- Serves as the compressor fluid storage sump.
- Houses the final fluid separator.

The compressed air/fluid mixture enters the receiver tank and is directed against the tank side wall. By change of direction and reduction of velocity, large droplets of fluid separate and fall to the bottom of the receiver tank. The fractional percentage of fluid remaining in the compressed air collects on the surface of the final separator element as the compressed air flows through the separator. As more and more fluid collects on the element's surface, the fluid descends to the bottom of the separator. A return line (or scavenge tube) leads from the bottom of the separator element to the inlet region of the compressor unit. Fluid collecting on the bottom of the separator element is returned to the compressor by the pressure difference between the area surrounding the separator element and the compressor inlet. An orifice (protected by a strainer) is included in this return line to help assure proper flow.

The receiver tank is code rated. A minimum pressure/check valve, located downstream from the receiver, helps assure a minimum receiver pressure of 65 psig (4.5 bar) during all conditions. This pressure is necessary for proper air/fluid separation and proper fluid circulation.

A minimum pressure/check valve is also used to prevent compressed air in the service line from bleeding back into the receiver on shutdown when the compressor is being run in parallel with other compressors tied to a large air system.

A pressure relief valve (located on the wet side of the separator) is set to ensure the receiver tank pressure will not exceed its rated pressure. A temperature switch will shut down the compressor if the discharge temperature reaches 250°F (121°C).

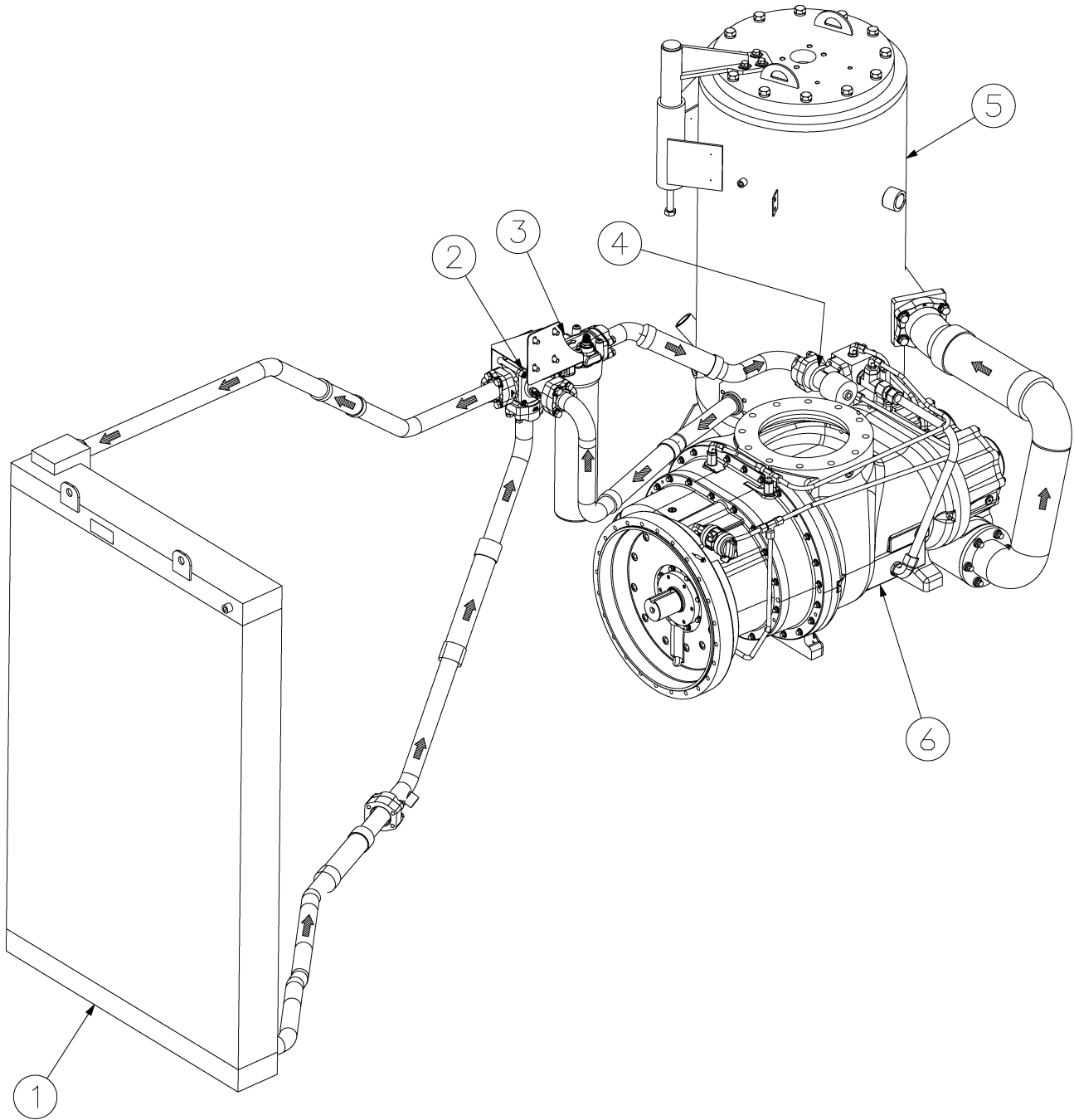

- | | |
|------------------|-------------------|
| 1. Fluid cooler | 4. Oil stop valve |
| 2. Thermal valve | 5. Receiver tank |
| 3. Fluid filter | 6. Air compressor |

Figure 2-2: Cooling and lubrication system

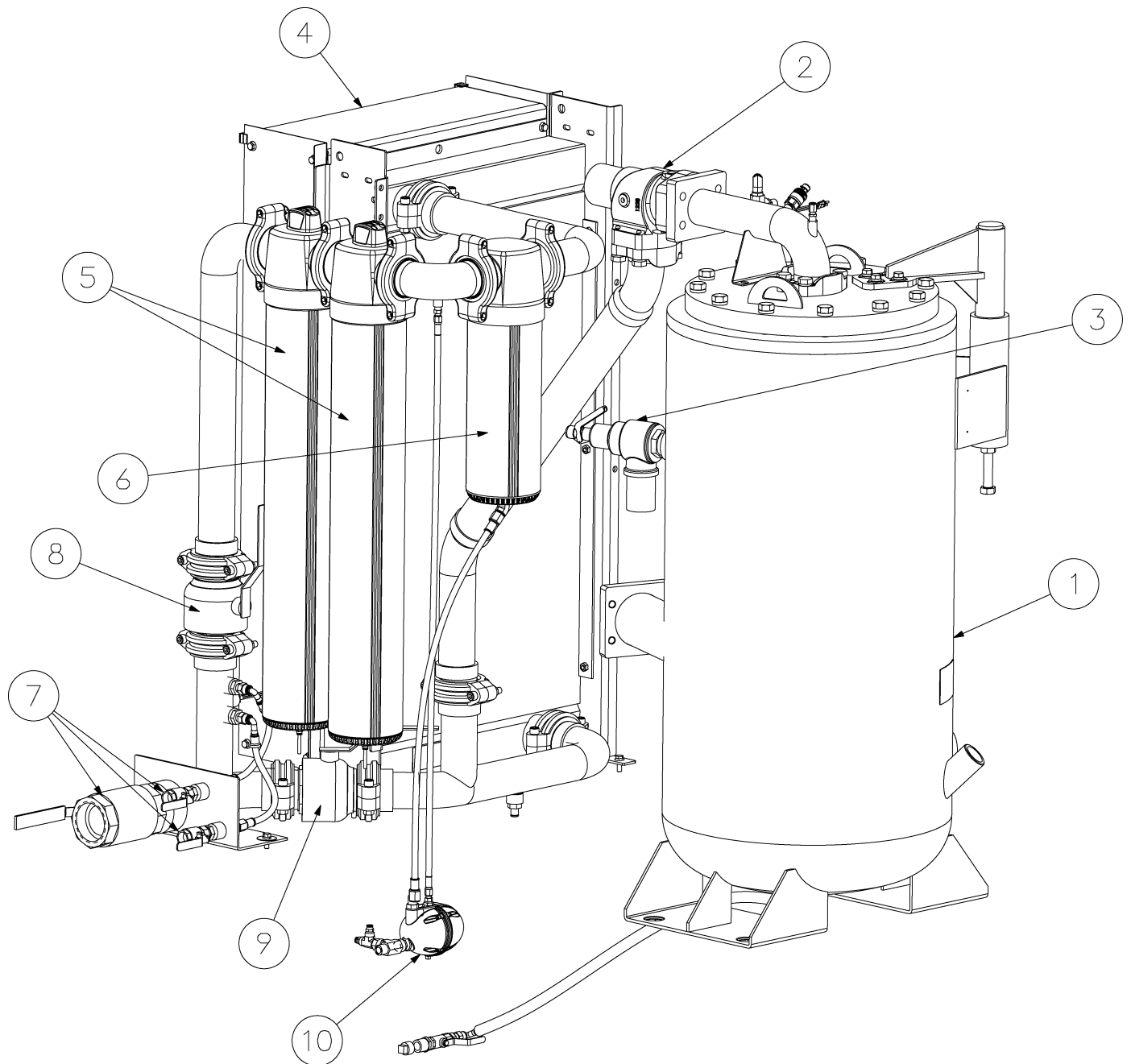

- | | |
|---------------------------------|--------------------------|
| 1. Receiver tank | 6. Water separator |
| 2. Minimum pressure check valve | 7. Service air valve |
| 3. Pressure relief valve | 8. Aftercooler air valve |
| 4. Aftercooler assembly | 9. Standard air valve |
| 5. Aftercooled air filters | 10. Moisture drain valve |

Figure 2-3: Discharge system (with optional aftercooler and discharge filter)

Fluid is added to the receiver tank via a capped fluid filler. A fluid level sight glass enables the operator to visually monitor the receiver tank fluid level.

WARNING

Do not remove caps, plugs, and/or other components when compressor is running or pressurized. Stop compressor and relieve all internal pressure before doing so.

2.6 Control system, functional description

Refer to *Section 2: Piping & instrumentation, compressor system* on page 34 and *Figure 7-3: Pneumatic control system* on page 66. The purpose of the control system is to regulate the amount of air intake in accordance with the amount of compressed air demand. The control system consists of an inlet valve, pressure regulator, a blowdown valve, the controller and a **LOAD** button.

Startup and warm up—0 to 65 psig (0 to 4.5 bar)

Push **OFF/ON/START** switch to **ON** position to initialize the controller. Once the Controller says “**READY**” on the display, press **OFF/ON/START** switch to the **START** position. In the **START** position, the start/run solenoid valve is de-energized and the inlet valve is held closed by pressure built up in the receiver tank. Air pressure is contained in the receiver tank by the minimum pressure valve which has a set point of 65 psig (4.5 bar). After engine has warmed up the machine automatically transfers to “**READY FOR AIR**” mode.

Running mode - 80 to 150 psig (5.5 to 12.4 bar)

With the controller in “**READY FOR AIR**” mode, compressor is now ready for use by pressing and holding the **LOAD** button for one second and opening the service valve. The machine is now in the “**AIR AVAILABLE**” mode where the start/run valve is energized allowing the inlet valve to open and the engine speed to increase to high idle (1800 rpm). As air demand decreases, service pressure and control pressure will rise. This is accompanied by a corresponding decrease in engine speed along with closing of the inlet valve. Ultimately, the compressor will unload and remain at low idle (1400 rpm) until an increase in air demand.

Shutdown

When the **OFF/ON/START** switch is set to **OFF** position, the start/run valve is de-energized closing the inlet valve

and opening the blowdown valve. The controller will display “**STOP INITIATED**” and the machine enters a cooldown period and the time remaining for cooldown will be displayed. After completion of the cooldown period, the engine will stop and the controller will remain powered and display “**MONITORING PRESSURES**”. Once system pressures are less than 10 psig, the controller will be powered off.

2.7 Air inlet system, functional description

The inlet system consists of two air filters, a compressor air inlet valve and interconnecting piping to the engine and compressor. Also, nylon tubing and air filter restriction indicator gauges are provided.

The air filters are a 2-stage unit with a safety element dry element-type filter. This filter is capable of cleaning extremely dirty air. However, in such cases, frequent checks of the air filter will be required. The compressor is equipped with restriction switches on both the engine and compressor inlet filters. When the set point is exceeded, the controller will display a message indicating it is time to replace the elements. At this time, change the air filter element. Refer to *Section 7.2: Daily operation and maintenance* on page 61.

The compressor air inlet valve controls the amount of air intake of the compressor in response to the air demand.

2.8 Engine control module, functional description

Diagnostic fault codes are provided to indicate an electrical or electronic problem has been detected by the ECM (Engine Control Module). In some cases, the engine performance can be affected when the condition causing the code exists. More frequently, however, the operator cannot detect any difference in the engine performance.

The controller indicates an engine performance problem has occurred whenever the engine warning lamp is flashing. The diagnostic code may indicate the cause of the problem, and should be corrected.

If the controller does not indicate a problem with the engine performance, but a diagnostic code is logged by the ECM, an abnormal condition was detected that did not affect performance.

If there is an error the controller will display the Failure Mode Indicator (FMI) and Suspect Parameter Number

(SPN) on the Engine Diagnostics page within the Service menu.

NOTE

Only active diagnostic codes can be read in this manner. Logged diagnostic codes must be retrieved with an electronic service tool.

Refer to the *Engine Operators Manual* for explanation and troubleshooting of active diagnostic and event codes.

2.9 Electrical system, functional description

Refer to *Section 2.10: Wiring diagram*. The electrical system is comprised of not only the necessary equipment required to operate the compressor, but also a system to shut it down in the event of a malfunction. The components of the electrical system are an engine starter (with an integral solenoid), battery, an alternator with a built-in voltage regulator, a compressor discharge temperature switch (which will shut down the compressor should the compressor temperature exceed 250°F [121°C]), a low coolant shutdown switch, low DEF shutdown, and low fuel shutdown protection. The engine coolant level detector is located in the radiator for the engine cooling system. It will shut the compressor down or prevent it from being started if the engine coolant level drops too low. In addition, there is a starter protection relay which prevents accidental starter engagement after the engine is running or whenever there is pressure in the receiver tank.

2.10 Wiring diagram

Subject to EAR, ECCN EAR99 and related export control restrictions.



02250220-244 R10 (sh1)

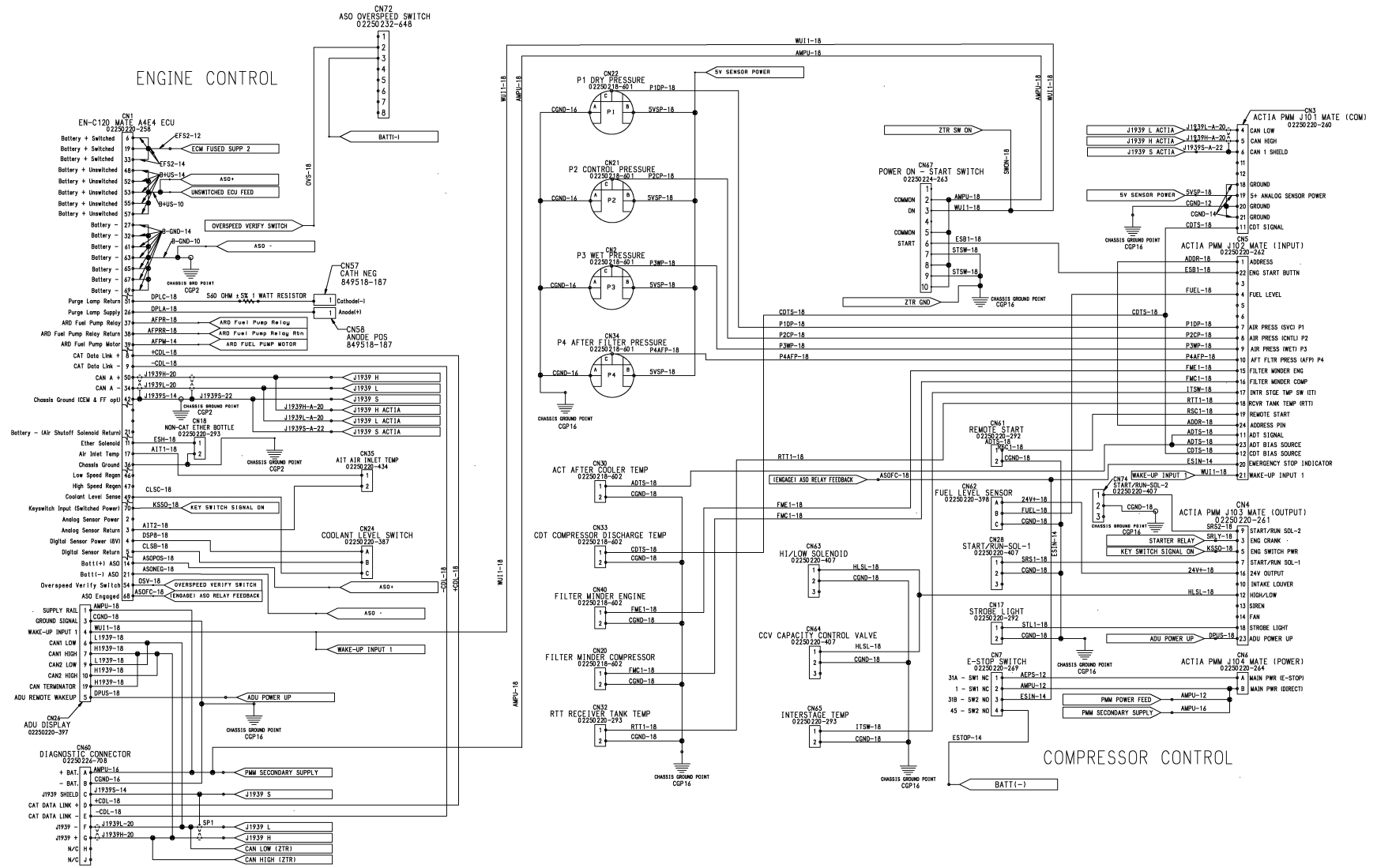

2.10 Wiring diagram

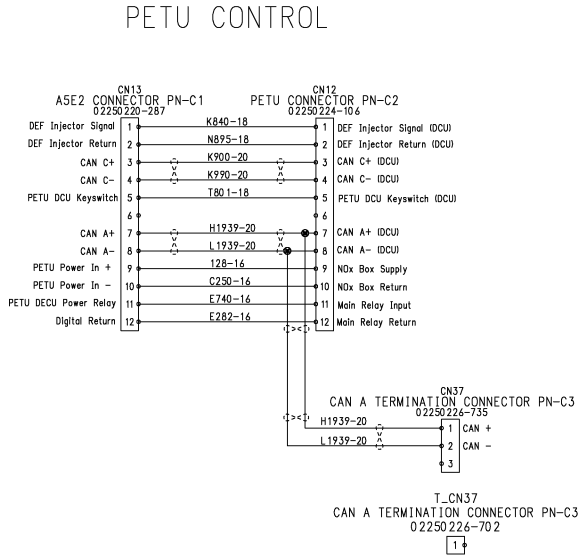

CEM CONTROL

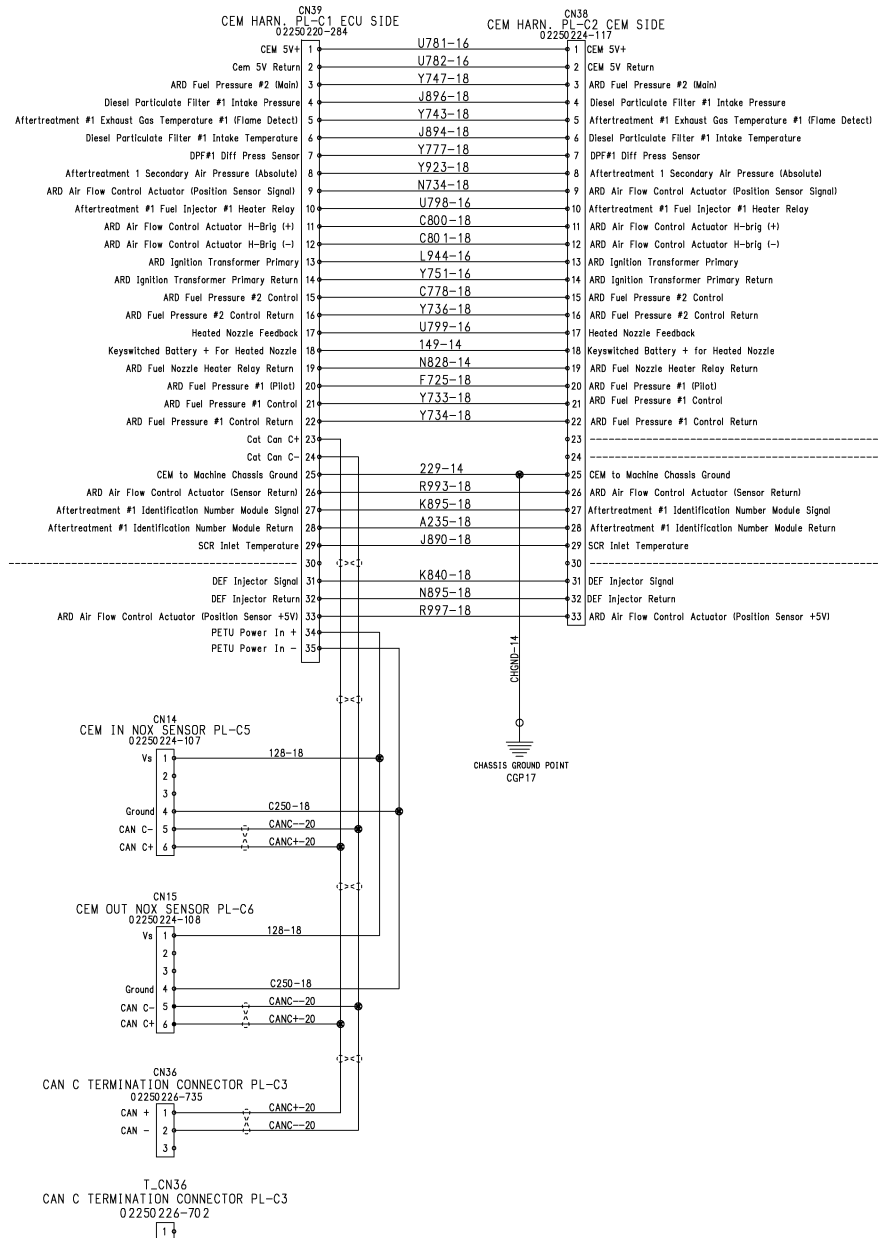

2.10 Wiring diagram

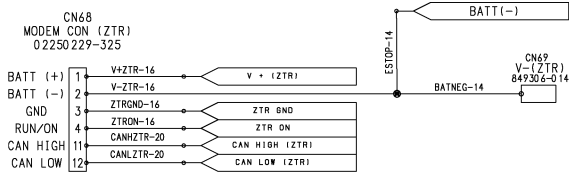
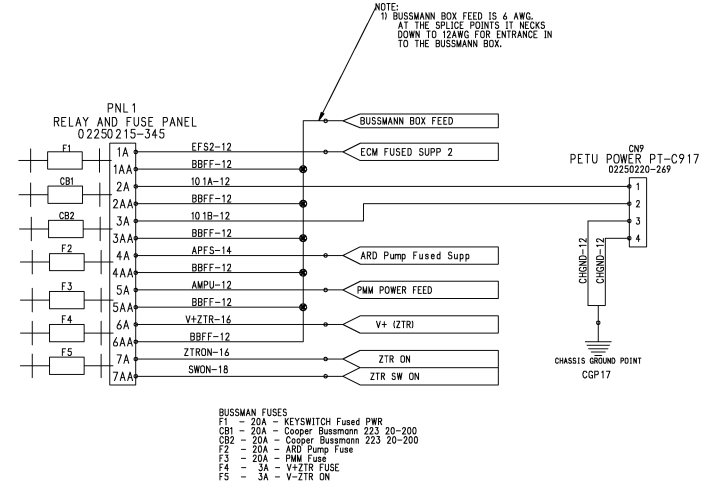
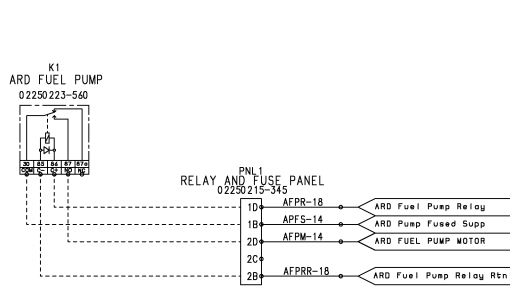

POWER DISTRIBUTION

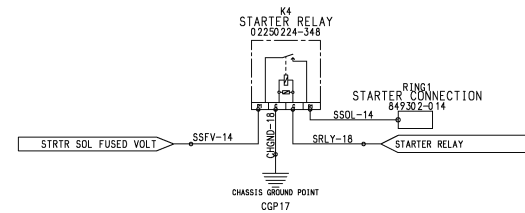
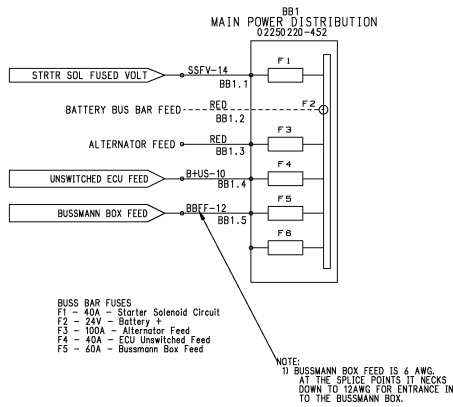

Subject to EAR, ECCN EAR99 and related export control restrictions.



02250220-244 R10 (sh3)

2.10 Wiring diagram

Drawing notes

1	ALL WIRE TYPES: GXL (MAY REPLACE WITH TXL)
2	ALL WIRE COLORS: WHITE UNLESS OTHERWISE SPECIFIED: e.g BB1.2 AND BB1.3 SEE 02250223-499
3	WIRE CROSSINGS WITHOUT A DOT ARE DISCONNECTED
4	WIRE CROSSINGS WITH A DOT ARE CONNECTED
5	CN36 AND CN37 MUST HAVE CAN TERMINATING (RESISTOR) MATING CONNECTOR (DT006-3S-P006) 02250226-702.

2.11 Piping & instrumentation, compressor system

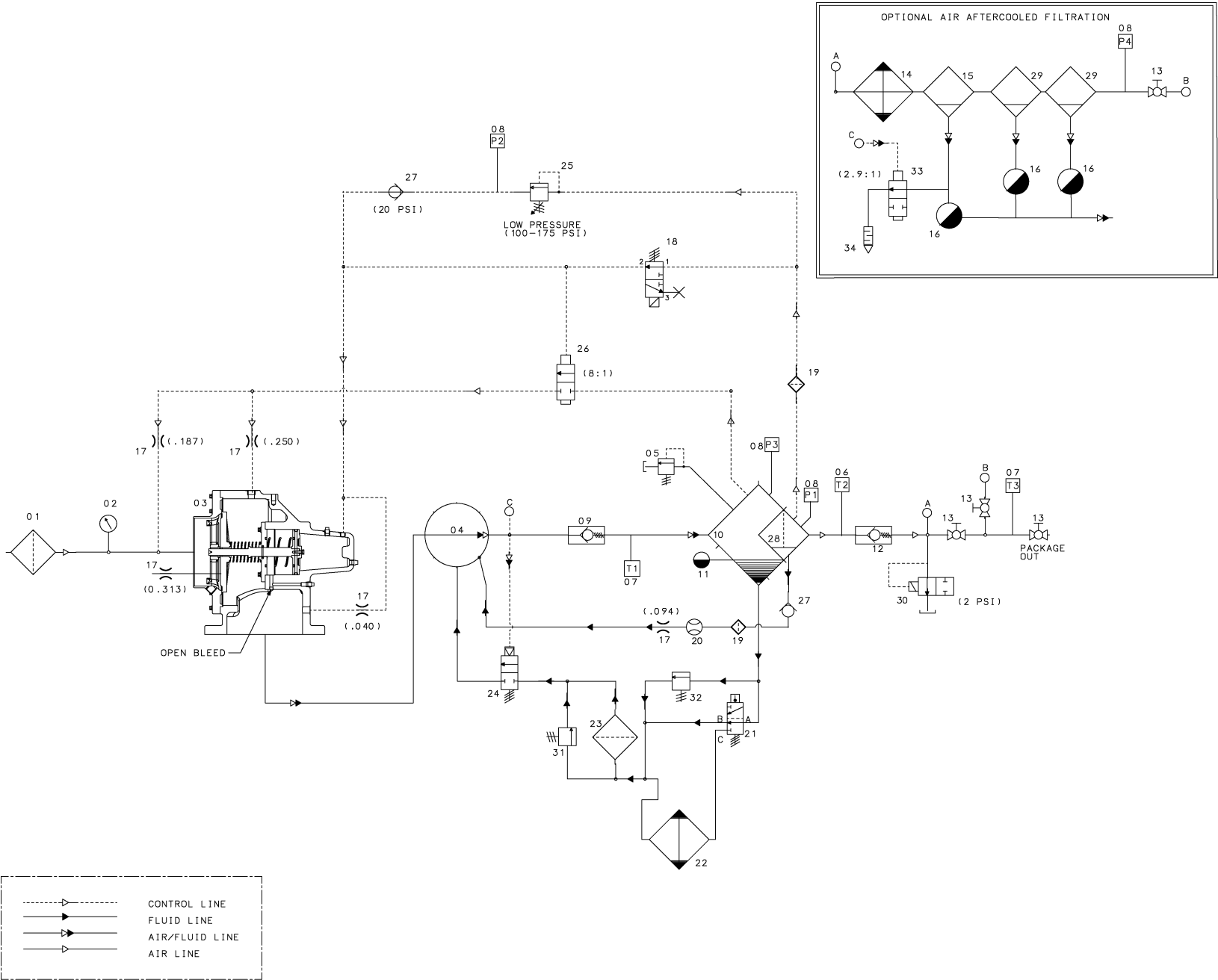

02250221-721 R05

2.11 Piping & instrumentation, compressor system

Key	Description
01	FILTER, AIR
02	GAUGE, AIR FILTER RESTRICTION
03	INLET VALVE
04	COMPRESSOR
05	VALVE, RELIEF
06	SWITCH, TEMPERATURE
07	SENSOR, TEMPERATURE
08	SENSOR, PRESSURE
09	VALVE, DISCHARGE CHECK
10	RECEIVER, AIR/OIL
11	GLASS, SIGHT OIL LEVEL
12	VALVE, MINIMUM PRESSURE
13	VALVE, BALL
14	COOLER, AIR
15	SEPARATOR, MOISTURE
16	TRAP, DRAIN
17	ORIFICE
18	VALVE, SOL 3WNO
19	STRAINER
20	SIGHTGLASS, ORIFICE BLOCK
21	VALVE, THERMAL BYPASS
22	COOLER, OIL
23	FILTER, OIL
24	VALVE, OIL STOP
25	VALVE, REGULATOR BACKPRESSURE
26	VALVE, BLOWDOWN N.C.
27	VALVE, CHECK
28	ELEMENT, AIR/OIL SEPARATOR
29	FILTER, AIR W/AUTOFLOAT
30	VALVE, ATMOSPHEREIC DRAIN
31	VALVE, FILTER BYPASS
32	VALVE, COOLER BYPASS
33	VALVE BLOWDOWN N.O.

Key	Description
34	SILENCER, BLOWDOWN

Component connections

Component	Description
P1	DRY SIDE PRESSURE
P2	CONTROL PRESSURE
P3	WET SIDE PRESSURE
P4	AFTERCOOLER FILTER DISCHARGE PRESSURE
T1	COMPRESSOR DISCHARGE TEMPERATURE (CDT)
T2	RECIEVER TANK TEMPERATURE (RTT)
T3	AFTERCOOLER DISCHARGE TEMPERATURE

2.12 ID, DTQ aftercooled

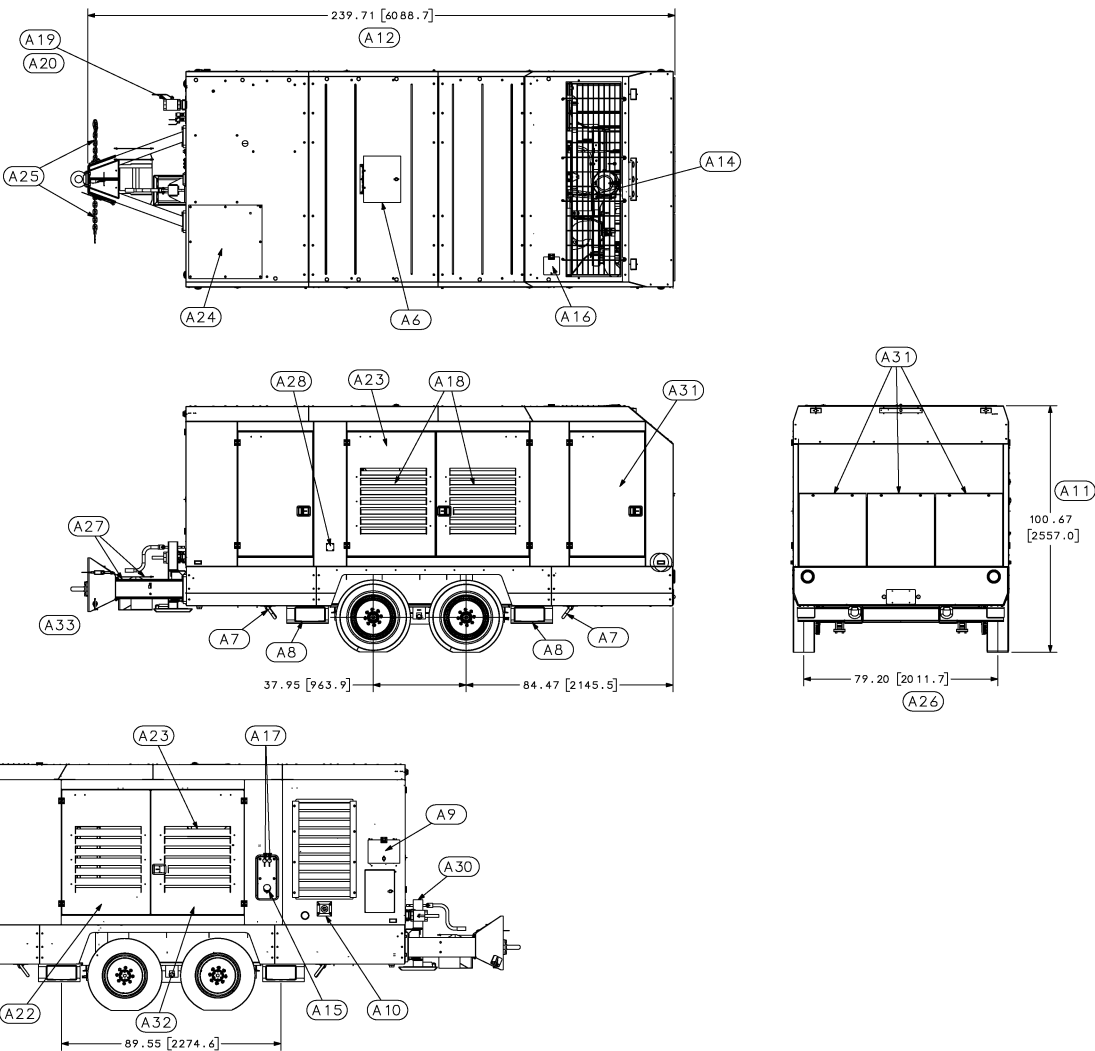

2.12 ID, DTQ aftercooled

Drawing notes

1	DIMENSIONS ARE IN INCHES. [] DIMENSIONS ARE IN MILLIMETERS.
2	ALL DOORS REQUIRE 39" [969 MM] CLEARANCE. ALL DOORS ARE PAD/KEY LOCKABLE.
3	APPROX. WET WEIGHT = 19,085 LBS. [8657 KG.], APPROX. DRY WEIGHT = 17,269 LBS. [7834 KG.]
A1	ENGINE COOLANT DRAIN
A2	ENGINE OIL DRAIN
A3	COMPRESSOR OIL DRAIN
A4	WATER CONDENSATE DRAIN (DO NOT PLUG) (ONLY REQ'D ON AFTER-COOLED MACHINES)
A5	FILTER/H2O TRAP ACCESS
A6	LIFTING BAIL ACCESS COVER
A7	TIEDOWN (4-PLACES)
A8	FORK LIFT POCKET
A9	INSTRUMENT PANEL DOOR
A10	EMERGENCY STOP BUTTON
A11	OVERALL HEIGHT
A12	OVERALL LENGTH
A13	OVERALL WIDTH
A14	AIR EXHAUST
A15	ENGINE FUEL FILL
A16	ENGINE COOLANT FILL
A17	ENGINE FUEL CONNECTION PORTS
A18	AIR INTAKE (4-PLACES)
A19	2" NPT AIR DISCHARGE (HP)
A20	3" NPT AIR DISCHARGE (LP)
A21	3/4" NPT AIR DISCHARGE (LP ONLY)
A22	BATTERY ACCESS
A23	AIR FILTER ELEMENT ACCESS (2-PLACES)
A24	AIR/OIL SEPARATOR ELEMENT ACCESS
A25	SAFETY CHAINS
A26	TRACK WIDTH
A27	WHEEL CHOCKS
A28	BLOCK HEATER INLET (OPTIONAL)
A29	STROBE LIGHT
A30	JACK
A31	AFTERTREATMENT ACCESS
A32	DEF ACCESS
A33	EYE HEIGHT 21.25 [539.8] TO 39.25 [997.0].

2.13 ID, DLQ aftercooled

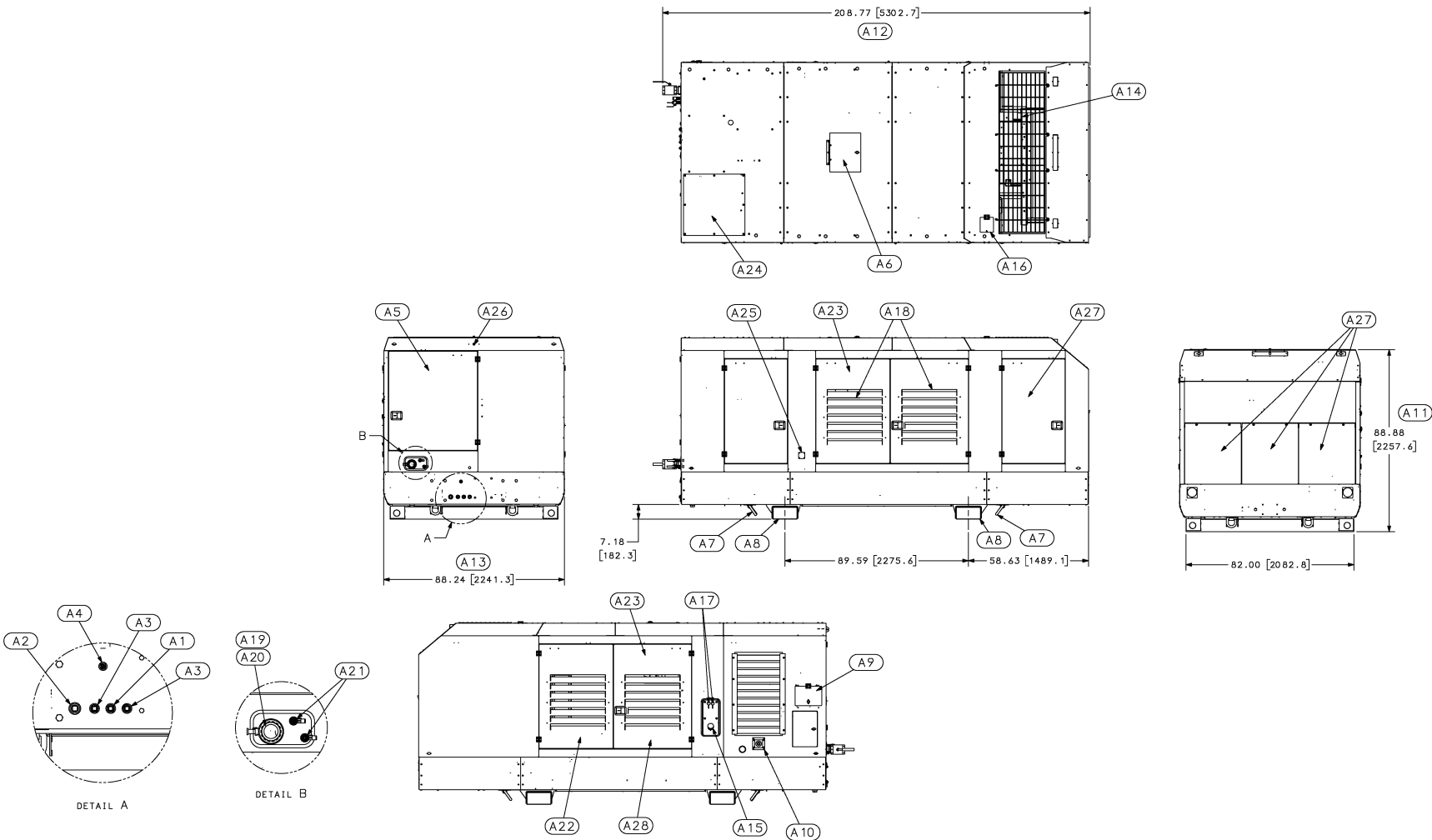

2.13 ID, DLQ aftercooled

Drawing notes:

1	DIMENSIONS ARE IN INCHES. [] DIMENSIONS ARE IN MILLIMETERS.
2	ALL DOORS REQUIRE 39" [969 MM] CLEARANCE. ALL DOORS ARE PAD/KEY LOCKABLE.
3	APPROX. WET WEIGHT = 17,577 LBS. [7973 KG.], APPROX. DRY WEIGHT = 15,761 LBS. [7149 KG.]
A1	ENGINE COOLANT DRAIN
A2	ENGINE OIL DRAIN
A3	COMPRESSOR OIL DRAIN
A4	WATER CONDENSATE DRAIN (DO NOT PLUG) (ONLY REQ'D ON AFTER-COOLED MACHINES)
A5	FILTER/H2O TRAP ACCESS
A6	LIFTING BAIL ACCESS COVER
A7	TIEDOWN (4-PLACES)
A8	FORK LIFT POCKET
A9	INSTRUMENT PANEL DOOR
A10	EMERGENCY STOP BUTTON
A11	OVERALL HEIGHT
A12	OVERALL LENGTH
A13	OVERALL WIDTH
A14	AIR EXHAUST
A15	ENGINE FUEL FILL
A16	ENGINE COOLANT FILL
A17	ENGINE FUEL CONNECTION PORTS
A18	AIR INTAKE (4-PLACES)
A19	2" NPT AIR DISCHARGE (HP)
A20	3" NPT AIR DISCHARGE (LP)
A21	3/4" NPT AIR DISCHARGE (LP ONLY)
A22	BATTERY ACCESS
A23	AIR FILTER ELEMENT ACCESS (2-PLACES)
A24	AIR/OIL SEPARATOR ELEMENT ACCESS
A25	BLOCK HEATER INLET (OPTIONAL)
A26	STROBE LIGHT
A27	AFTERTREATMENT ACCESS
A28	DEF ACCESS

2.14 Aftercooler air system, functional description

Refer to *Figure 2-3* on page 27. The purpose of the aftercooler air system is to operate the air compressor in conditions when compressed air temperatures are required to be 10 to 25°F (5 to 13°C) over ambient temperature. This compressor has one main discharge valve. The discharge plumbing within the compressor allows the user to switch between standard air to aftercooled and filtered air through a set of valves. These valves are labeled on the machine to help assist the user to select the proper valve orientation with respect to the type of air that is required for the application.

Depending upon the application, the compressed air can be by-passed around the aftercooler for unprocessed air or it can be routed through the aftercooler for cooling. The ambient air, which is drawn through the aftercooler by the engine fan, cools the compressed air as it passes through the aftercooler core. Cooled air enters the moisture separator where condensate is removed and discharged. This condensate does carry some oil and it should be disposed of properly in accordance with local regulations. From the moisture separator the compressed air goes to the compressor service valve.

NOTE

Aftercooler system should not be operated in ambient conditions below 32°F (0°C).

To operate in the non-aftercooled mode, close the aftercooler valve completely and open non-aftercooler valve.

2.15 Engine exhaust aftertreatment, functional description

The compressor is equipped with exhaust aftertreatment equipment to meet U.S. EPA Tier 4 Final and EU Stage IV emissions requirements. Major components include

the Clean Emissions Module (CEM) and Pump Electronics Tank Unit (PETU). The CEM is an integrated assembly containing the Diesel Particulate Filter (DPF), Diesel Oxidation Catalyst (DOC), Selective Catalytic Reduction (SCR) and all required connections and control components. The PETU contains and controls injection of diesel exhaust fluid (DEF) into the CEM. These parts in conjunction with the rest of the engine systems are responsible for reducing particulate and Oxides of Nitrogen (NOx) to meet regulations.

On a periodic basis, the CEM will undergo an active regeneration event. This event is controlled in one of two ways:

1. Automatically controlled by engine ECM, or
2. Requested by end user via controller.

During this event, diesel fuel and air is added and ignited in the CEM resulting in elevated temperatures.

Tier 4 Final regeneration strategy differs greatly from Tier 4 Interim. The primary reason for active regeneration in Tier 4 Interim was to reduce soot load accumulation in the DPF. For Tier 4 Final, passive regeneration is primarily responsible for soot reduction.

Active regeneration can still occur in the following conditions/frequency:

- Cold start-up regeneration: Upon cold start-up (coolant temp < 104°F [40°C]).
- DPF soot level: As required to reduce soot load. Infrequent in this installation.
- Maintenance: To cycle fuel in regeneration system. Approx. every 25 hours.)

WARNING

Regenerated exhaust gases can reach temperatures of up to 1800°F (982°C). Do not come into direct contact with these gases.

Section 3

Specifications

3.1 Specifications—1600H Tier 4 Final Perkins

Table 3-1: Package specifications

Model series	1600H	
Package	DTQ (tandem axle)	DLQ (less running gear)
Package	DTQ (tandem axle)	DLQ (less running gear)
Weight (working) ^{†‡}	lbs (kg)	19085 (8657)
Weight (dry) ^{†‡}	lbs (kg)	17577 (7973)
Length	in (mm)	239 (6071)
Width	in (mm)	88 (2235)
Height	in (mm)	89 (2261)
Track width	in (mm)	79.2 (2012)
Maximum towing speed	mph (km/h)	65 (104)
Axle rating	lbs (kg)	9000 (4091)
Tire size		215/75R17.5
Tire pressure	psi (bar)	125 (8.6)
Wheel size		17.5
Lug nut torque	lbf ft (N m)	300 (407)
[†] Weight is for an aftercooled and filtered machine. A standard air machine reduces weight by 360 lbs (163 kg). [‡] Weight is approximate and varies by options installed.		

Table 3-2: Compressor specifications

Model series	1600H	
Type	Rotary screw	
Actual delivery	cfm (L/s)	1600 (755)
Rated pressure	psig (bar)	150 (10.3)
Pressure range, min.	psig (bar)	80 (5.5)
Pressure range, max. (unloaded)	psig (bar)	175 (12.0)
Service valves	1 (3" NPT)	
Service valves, auxiliary	2 (.75" NPT)	
Cooling	Pressurized compressor fluid	
Lubricating compressor fluid	AWF [®]	
Compressor fluid capacity	gal (L)	40 (151)
Operating tilt (maximum)	15°	
Sound level (U.S. EPA) [†]	dBA	76
Electrical system, instrument	voltage	24 VDC
[†] Sound level measured per US 40 CFR Ch.1 Part 204.		

Table 3-3: Engine specifications

Model		1600H
Type		Diesel
Make		Perkins
Model		2506J
Emissions level	U.S. EPA	Tier 4 Final
Displacement	in ³ (L)	928 (15.2)
Cylinders		6
Cycles		4
Operating speed	rpm	1800
Minimum idle speed ¹	rpm	1400
Available power, SAE	bhp (kW)	540 (403)
Electrical system, engine	voltage	24 VDC
Battery rating (2)	CCA	1700 CCA @ 32°F(0°C)
		(8D) 1400 CCA @ 0°F (-18°C)
Alternator	amp	95
Radiator capacity	gal (L)	21.6 (81.8)
Engine water shutdown temperature	°F(°C)	219 (104)
Lubricating system		Full pressure fluid
Type of motor oil		See <i>Engine Operator's Manual</i>
Engine oil capacity	gal (L)	19 (72)
Fuel tank capacity	gal (L)	249 (943)
DEF capacity	gal (L)	12.8 (48.4)
¹ Do not allow engine idle rpm to drop below minimum idle speed. Compressor and/or coupling damage will occur. The compressor is equipped with a low speed shutdown system that will shut down the compressor if engine speed falls below 1100 rpm.		

3.2 Lubrication guide—compressor

Fluid type	Change period, hours	Ambient temperature range	
		°F	°C
Sullair AWF [†]	1500	-20 to 120	-29 to 49

[†]Sullair AWF part numbers: 250030-757 (5 gallons/18.9 liters) and 250030-758 (55 gallon/208 liter drum).

3.3 Lubrication guide—engine

Refer to the *Engine Operator’s Manual* for engine oil specifications.

3.4 Application guide

Sullair portable air compressors are filled with Sullair AWF[®]. Sullair AWF is a heavy-duty, multi-viscosity, all-weather fluid suitable to a wide variety of conditions, including conditions that can cause severe fluid oxidation.

In high ambient temperature and high humidity conditions, condensed moisture can emulsify with the fluid (indicated by the fluid turning a “milky” color). Change the fluid if this condition develops.

Do not mix different types or brands of fluid. Mixing different types or brands of fluids can lead to operational problems such as foaming, plugged filters, blocked orifices or lines, or even severe problems like a plugged cooler or a locked air end.

Contact your Sullair representative for fluid recommendations if operating conditions require the use of an extended life fluid (for example, the ambient temperature is outside the recommended temperature range for Sullair AWF).

Sullair encourages users to participate in a fluid analysis program. The analysis might indicate a need for change intervals different from those recommended in this manual (for example, to maximize the life of the machine in dirty environments). Contact your Sullair representative for details.

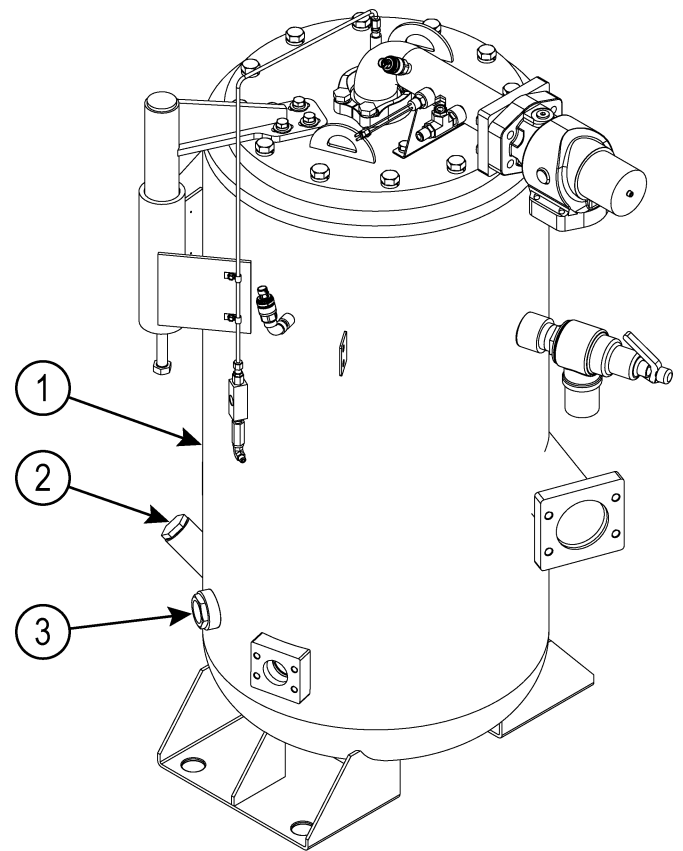

- 1. Receiver/tank
- 2. Fluid fill port
- 3. Sight glass

Figure 3-1: Fluid fill location

NOTE

Proper compressor fluid level visible halfway in fluid sight glass when checked on a level surface with the compressor not running.

Notes:

Section 4

Installation

4.1 Locating the package

Position the compressor on a level surface, if possible. If unable to locate the compressor on a level surface, position the compressor on a grade surface which will not allow the compressor to slide downhill.

Do not locate compressor on surface grades exceeding 15 degrees.

The compressor package should be placed on a surface or foundation capable of supporting 10% more than the compressor weight. Take into consideration additional weight allowances for stored tools, rainwater, snow, ice and mud.

No piping loads or moments should be transmitted to the air and fuel connections provided with the package.

Locate compressor so the wind, if any, will help carry the exhaust fumes and package heat away from the compressor air inlet openings. The compressor coolers should not be exposed to excessive dust from the work-site. Contaminants on the coolers will directly affect the packages ability to run in high ambient temperatures.

4.2 Ventilation and cooling

Select a location that allows an unrestricted flow of free ventilation air through the package.

Avoid any recirculation or ingestion of heated gases.

Compressor and engine intakes are located on the double set of doors on the engine and compressor side. Engine and compressor cooling air intake is also taken from the double set of doors while aftercooler cooling air intake has a dedicated opening. Canopy discharge (for cooling air) and engine exhaust is located on the roof at the rear of the package.

Maintain a 6 ft. (1.8 m) minimum separation between the package and any surrounding walls.

If ductwork is installed, the total restriction on intake must not exceed 0.1 inches H₂O (25 pascals). The total restriction on the outlet must not exceed 0.1 inches H₂O (25 pascals).

4.3 Service air and condensate piping

A shut-off valve is included to isolate the package from the supply line as required.

No piping loads or moments should be transmitted to the air connections provided with the package.

Condensate drains shall be connected to a non-pressurized gravity feed drain. If the compressor drains are manifolded together, care should be taken to ensure that this drain is not pressurized when the machine condensate drains (both automatic and manual) are in operation.

All condensate should be disposed of in accordance with local governing laws.

4.4 Remote fuel connections

This compressor is provided with a fuel selector valve and quick disconnect fittings to allow connection to a remote fuel tank. Supply and return connections as well as selector valve position are shown in *Figure 4-1* and *Figure 4-2* on page 46. External fuel connecting hose length is limited to 25 ft. of 3/4" hose to provide sufficient fuel pressures to the engine and avoid damage to the fuel pump. When operating with an external fuel tank and an empty on-board tank, it is necessary to select "**External Tank**" on the controller to avoid low fuel warnings and shutdowns. Refer to *Section 6: Controller* for details on this setting.

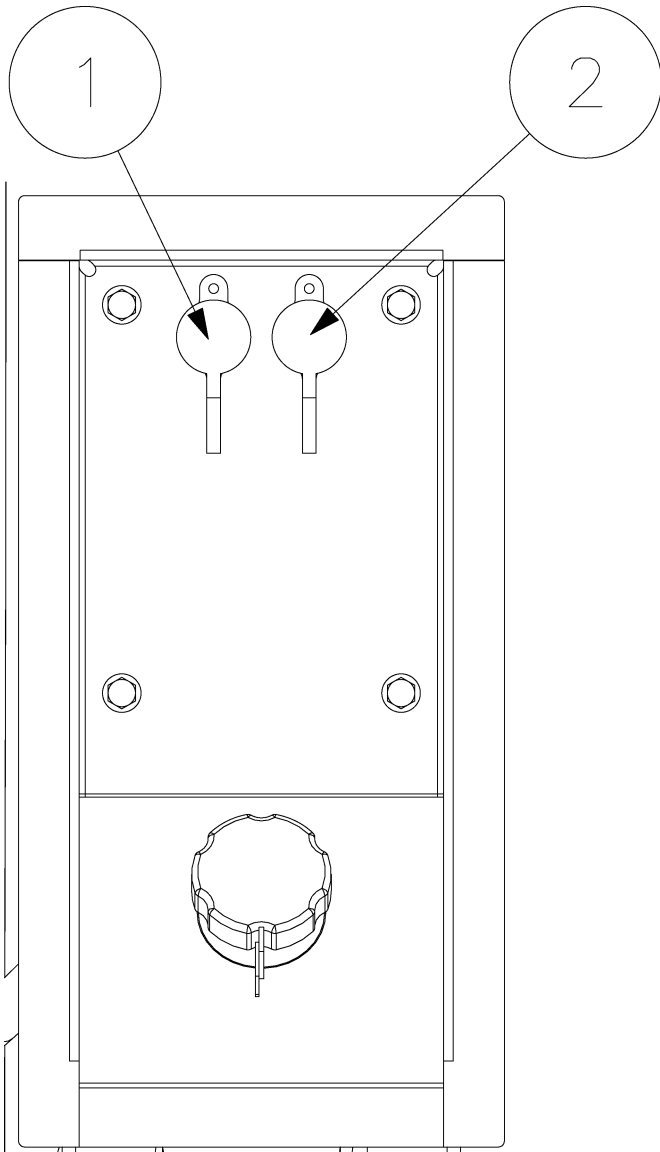

- 1. Fuel return
- 2. Fuel supply

Figure 4-1: External fuel connections

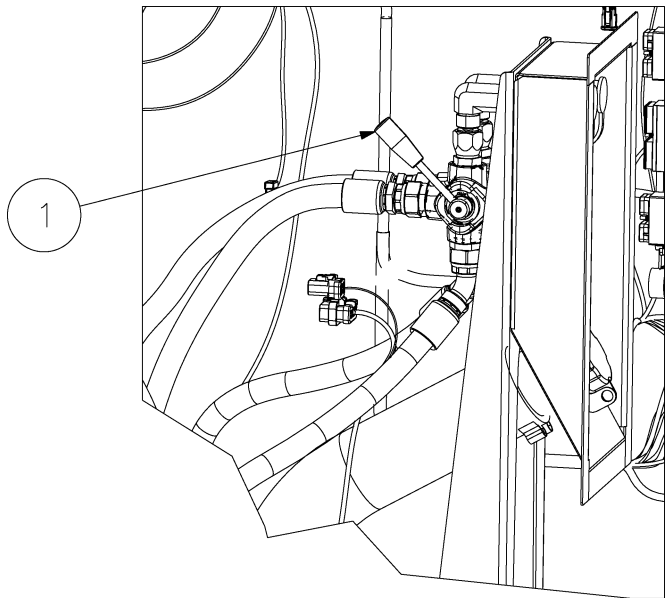

- 1

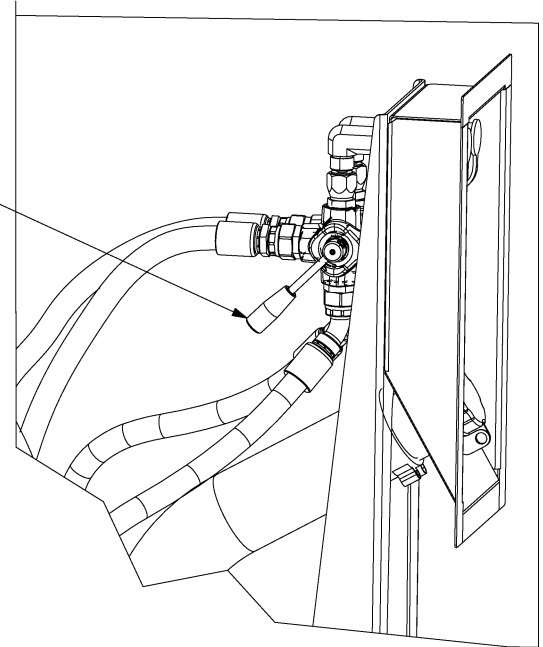

- 1. External tank
- 2. On-board tank

Figure 4-2: Fuel tank selector valve positions

Section 5

Operation

5.1 General

While Sullair has built into this compressor a comprehensive array of controls and indicators to assure you that it is operating properly, you will want to recognize and interpret the readings which will call for service or indicate the

beginning of a malfunction. Before starting your Sullair compressor, read this section thoroughly and familiarize yourself with the controls and indicators—their purpose, location and use.

5.2 Purpose of controls

Control or indicator	Purpose
OFF/ON Switch / START Switch (Up) [†]	The engine switch is used to both energize the compressor's electrical system and engage the engine/starter. It also has a built-in anti-restart device that protects the starter from engaging while the engine is running. The switch must be turned back to the "off" position before the engine can be re-started.
	<div style="background-color: black; color: white; padding: 5px; font-weight: bold;">NOTE</div> <p>When restarting the compressor, the controller will not allow restart until system pressure falls below 10 psig (0.7 bar) or less. More than 10 psig (0.7 bar) can put extra load on the starter.</p>
Voltmeter [†]	Monitors the condition of the batteries and the charging circuit. The normal reading is 24 to 28 volts.
Service Air Pressure [†]	Continually monitors the pressure inside the receiver tank at various load and unload conditions.
Engine Temperature [†]	Monitors the temperature of the engine water. The normal operating temperature should read approximately 160°F to 210°F (71°C to 99°C).
Controller [†]	Depicts system related diagnostics. Can be used for system performance monitoring.
Compressor Temperature [†]	Monitors the temperature of the air/fluid mixture leaving the compressor unit.
Fluid Level Sight Glass	Monitors the fluid level in the receiver tank. Proper level is always visible in the sight glass. Check the level when the compressor is shutdown.

[†]Indicates item is part of the compressor controller.

Control or indicator	Purpose
Receiver Tank Temperature Switch	Opens the electrical circuit to shut down the compressor when the receiver tank temperature reaches 250°F (121°C).
Control Regulating Valve	Provides an air signal to the inlet valve and engine to close the inlet valve and reduce engine speed to control air delivery according to demand.
Minimum Pressure/Check Valve	Maintains a minimum of 65 psig (4.5 bar) in the compressor receiver tank. This valve restricts receiver air discharge from receiver/receiver tank when pressure falls to 65 psig (4.5 bar). Also prevents back flow into the receiver tank during upload conditions and after shutdown.
Pressure Relief Valve	Opens receiver tank pressure to atmosphere should pressure inside the receiver tank exceed the pressure relief valve setting.
Air Inlet Valve	Regulates the amount of air allowed to enter the compressor. This regulation is determined by the amount of air being used at the service line.
Thermal Valve	Regulates flow of fluid to and around the fluid cooler. Designed to maintain a minimum operating temperature; used for fast warm-up at start-up and to eliminate condensation during operation.
Blowdown Valve	Vents surplus receiver tank pressure during operation and shutdown.
Engine Coolant Level Switch	Shuts the compressor down and/or prevents it from being started if the engine coolant level drops too low.

[†]Indicates item is part of the compressor controller.

5.3 Startup procedure

- Turn on the system power supply by turning the battery disconnect switch to the **ON** position.
 - For the location of the battery disconnect switch, see *Figure 2-1* on page 24 and *Figure 5-1* on page 50.
- Toggle the **<OFF/ON/START>** switch, located on the controller, to the **ON** position.
 - The controller will power up and initialize. Also, a communication link will be established with the engine ECU. When the system has successfully initialized, the controller status will read **"READY"**.
- Toggle the **<OFF/ON/START>** switch to the **START** position.
 - You do not have to hold the switch in the **START** position. The controller status will read **"ENGINE CRANKING"**

WARNING

If the machine does not start successfully when starter disengages, the starter will automatically engage up to three times (total) after brief pauses to try and start the machine.

- Once the compressor has started, the unit will enter a warm-up phase and the controller status will read **"WARM UP CYCLE"**. At this point, the unit is not producing usable compressed air and the service valve should still be closed.
- Once the proper operating conditions are met, the machine will be ready to deliver air and the controller status will display **"READY FOR AIR"**.

5.4 Operation procedure

- Once ready to use air, press the **<LOAD>** button and the machine will begin to deliver usable air.

- The controller status will display “**AIR AVAILABLE**”.
2. At the same time, the service valve should be opened and set to maintain the desired operating pressure.

NOTE

Fully opening the service valve can result in low service pressure and an overflow condition. This overflow condition can result in excessive oil carry-over in addition to reduced air delivery as the compressor slows to low idle rpm.

5.5 Shutdown procedure

WARNING

The E-Stop (emergency stop switch) should be used only in the event of an emergency. Refrain from using the E-Stop to shut the machine down during normal operations or equipment damage can occur. All usage of the E-Stop is logged in permanent memory for use by service technicians when troubleshooting a machine. Non-emergency use of E-Stop is considered equipment abuse and could void the manufacturer's warranty.

1. Slowly close the service valve.
2. Place the **<OFF/ON/START>** switch in the **OFF** position.
 - The controller status will read “**STOP INITIATED**” and the compressor will enter the cooldown period.
3. The unit will continue to run at low idle rpm, though it will not produce usable air. At the end of the cool down cycle, the engine will be shut down.
 - The controller will stay powered up while displaying a status of “**MONITORING PRESSURES**”.
 - The controller will continue to monitor the system pressures and will not power down until all pressures drop below 2 psi (0.14 bar). This final process may take 3 to 5 minutes. Operator interaction is not necessary during this time as the controller will automatically disconnect power to all sys-

tems so that the battery is not inadvertently drained after shutdown.

WARNING

Following engine shutdown, the exhaust after-treatment will initiate a purge procedure to clear remaining DEF from the lines. This is necessary to prevent damage to the DEF injector from flooding or freezing. A light is provided near the battery disconnect to notify the user when the purge cycle is active (see *Figure 5-1* on page 50). Do not turn battery disconnect switch to off when this lamp is lit or damage to the after-treatment could occur and an engine fault code may be triggered.

4. Turn off the system power supply by turning the battery disconnect switch to the **OFF** position.
 - For the location of the battery disconnect switch, see *Figure 2-1* on page 24 and *Figure 5-1* on page 50.

WARNING

It is a good practice to engage the battery disconnect after use. The engine and the compressor controller systems continually draw power after the controller is powered down. Over time, this will deplete the batteries. If the batteries are left on per application requirements, like remote start applications, a battery maintainer should be used to keep the batteries fully charged.

5. Vent all external pressure (pressure downstream of the machine) before disconnecting any air tools, hoses, fittings, etc.

WARNING

Pressure hazard

Failure to vent external pressure can result in serious injury.

Vent all external pressure (pressure downstream of the machine) before disconnecting any air tools, hoses, fittings, etc. or performing any maintenance procedures.

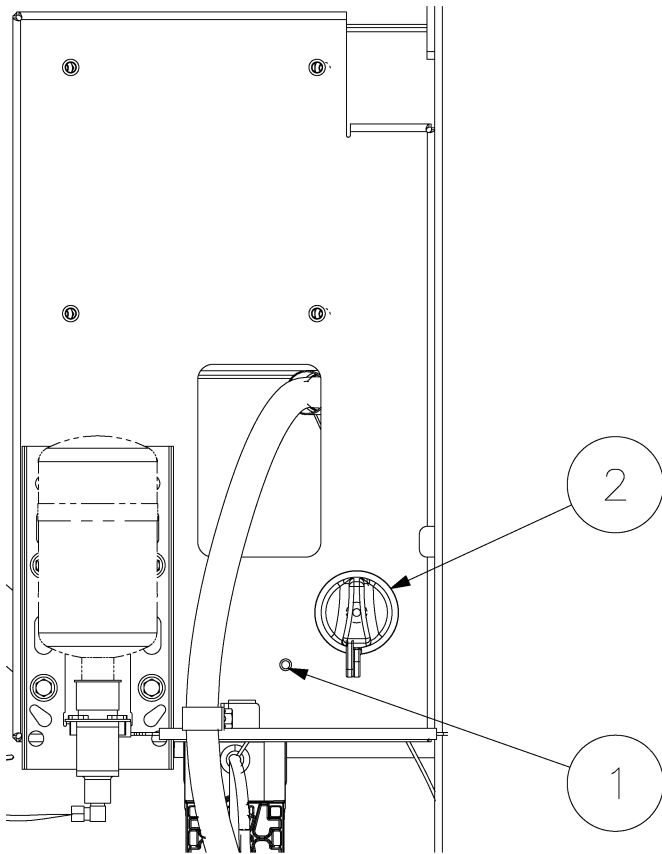

- 1. Purge lamp
- 2. Battery disconnect switch

Figure 5-1: Purge lamp location

Section 6

Controller

6.1 Controller layout

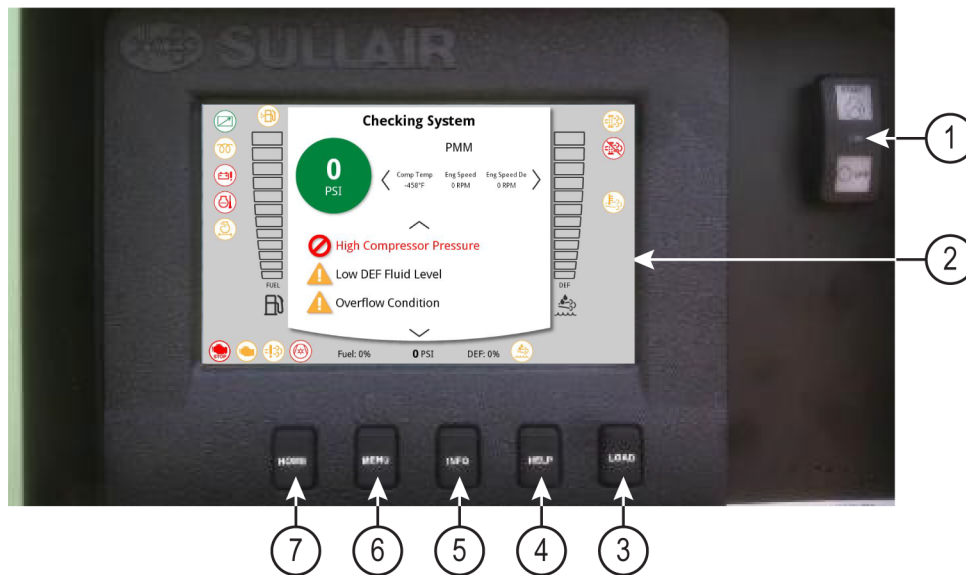

Key	Description	Function
1.	ON/OFF/START switch	Used to turn controller on and start or stop machine.
2.	Display	Touch screen display. Used to display operating parameters and machine information. Also used to access additional machine functions.
3.	LOAD button	When machine is in “Ready for Air” state, the button is pressed and held for one second to begin delivering usable air. Can also be used to unload machine during periods of no air demand.
4.	HELP button	Calls up a menu with machine operating instructions, troubleshooting and QR code.
5.	INFO button	Calls up a screen showing compressor and engine operating parameters.
6.	MENU button	Calls up a sub-menu with User Options, Service Options and the Help menu.
7.	HOME button	Returns to home screen.

Figure 6-1: Controller layout and button functions

6.2 Home display

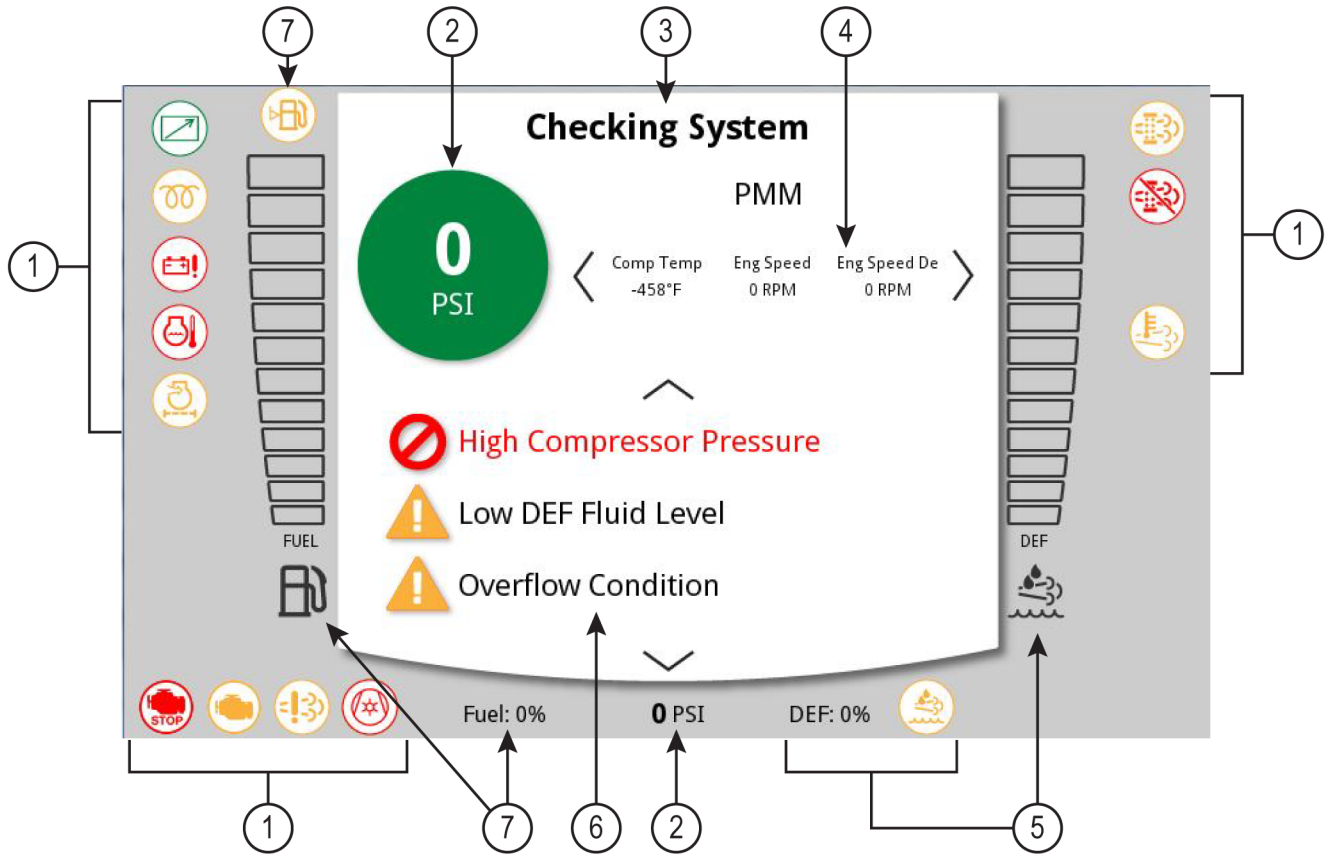

- | | |
|----------------------------|--|
| 1. Indicator lamps | 5. Diesel exhaust fluid (DEF) level gauges |
| 2. Service pressure gauges | 6. Message bar |
| 3. Status bar | 7. Diesel fuel level gauges |
| 4. Information bar | |

Figure 6-2: Home display layout

Table 6-1: Home display items and functions

Key	Description	Function
1	Indicator lamps	Displays status and malfunction indicator lamps. See <i>Section 1.15: Symbols and references</i> on page 12 for definitions of symbols.
2	Service pressure gauges	Displays service (tank) pressure.
3	Status bar	<p>Displays current operating status of compressor:</p> <p>READY: Controller is initialized and compressor is ready to start.</p> <p>ENGINE CRANKING: Starter is engaged and cranking engine.</p> <p>WARM UP CYCLE: Engine is started and compressor is in warm-up state.</p> <p>READY FOR AIR: Warm-up cycle is complete and machine is ready to deliver air.</p> <p>AIR AVAILABLE: LOAD button has been pressed, air is being delivered and compressor is operating in automatic mode.</p> <p>STOP INITIATED: Switch has been turned to off and compressor is in cool-down period.</p> <p>MONITORING PRESSURES: Engine is stopped and controller is monitoring pressures until less than 2 psig (0.14 bar) before controller is turned off.</p>
4	Information bar	Displays compressor and engine parameters. Left and right arrows can be used to scroll through parameters. Can also be accessed by pressing INFO button.
5	Diesel exhaust fluid (DEF) level gauges	Displays remaining level of DEF. A warning message will be provided on low DEF level. Engine de-rate and shutdowns will occur if DEF is not refilled.
6	Message bar	Displays service reminders and warning/fault messages.
7	Diesel fuel level gauge	Displays remaining level of fuel. A warning message will be provided on low fuel level. The controller will shut the compressor off on very low fuel level in order to protect the engine.

6.3 User options

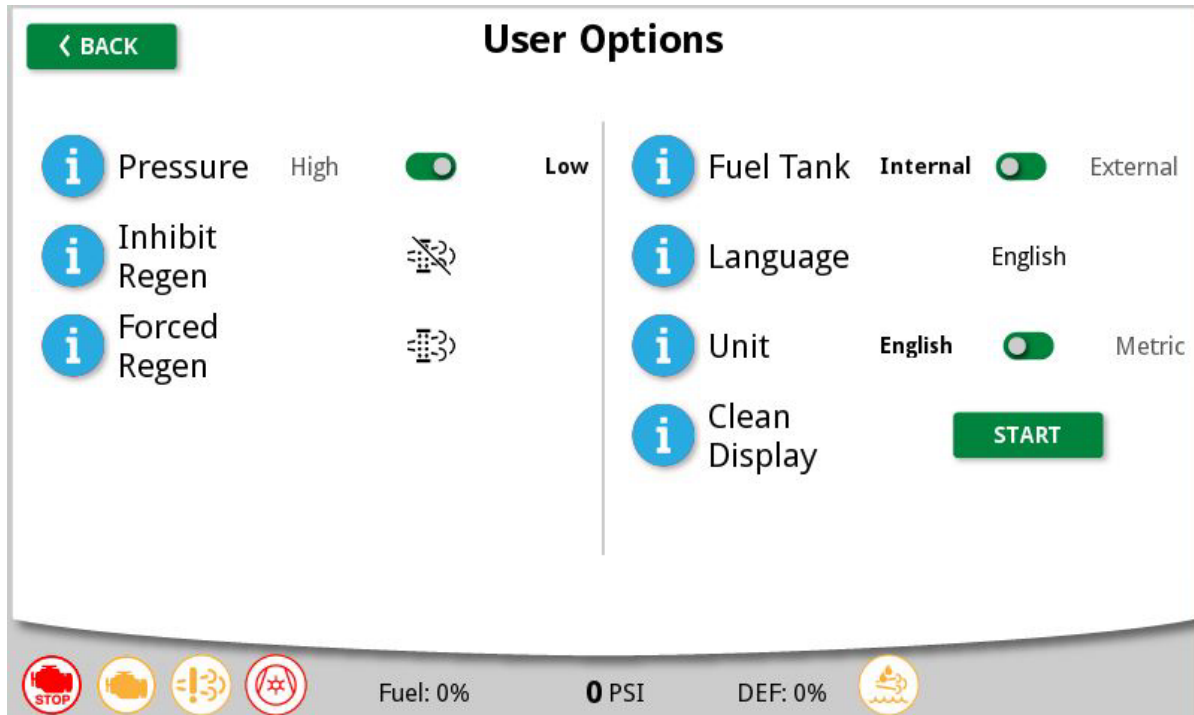

Figure 6-3: User options layout

User options are accessed via the physical **MENU** button on the front of the controller. The **i** icon next to the setting provides a brief description. Note that some settings can be locked out by the renter of the equipment and may not be available to the end user.

- **PRESSURE:** Provides for selection between high and low operating pressure mode. Move toggle to high or low depending on need. May not be available on all models. Refer to *Section 5.4* on page 55 for the proper setting procedure.
- **INHIBIT REGEN:** Can be used to inhibit regeneration of the engine aftertreatment if high exhaust temperatures are a concern. Press and hold to inhibit. Excessive use of the inhibit function can result in engine de-rate/shutdowns and ultimately damage to engine aftertreatment components.

- **FORCED REGEN:** This is used to (a) cancel and inhibit and put regeneration into automatic control (via engine ECM) and (b) actively force a regeneration event. A regeneration event will only commence if certain engine conditions are met.
- **FUEL TANK:** Includes toggle for selecting between internal and external fuel tank. If external fuel tank is selected, fuel gauge is no longer displayed and low fuel level faults and warnings are not active.
- **LANGUAGE:** Select display language.
- **UNIT:** Select English or metric units of measurement.
- **CLEAN DISPLAY:** When this is selected, touch screen selections are temporarily disabled allowing the screen to be cleaned. Screen may be cleaned with mild soap and water.

6.4 Service options

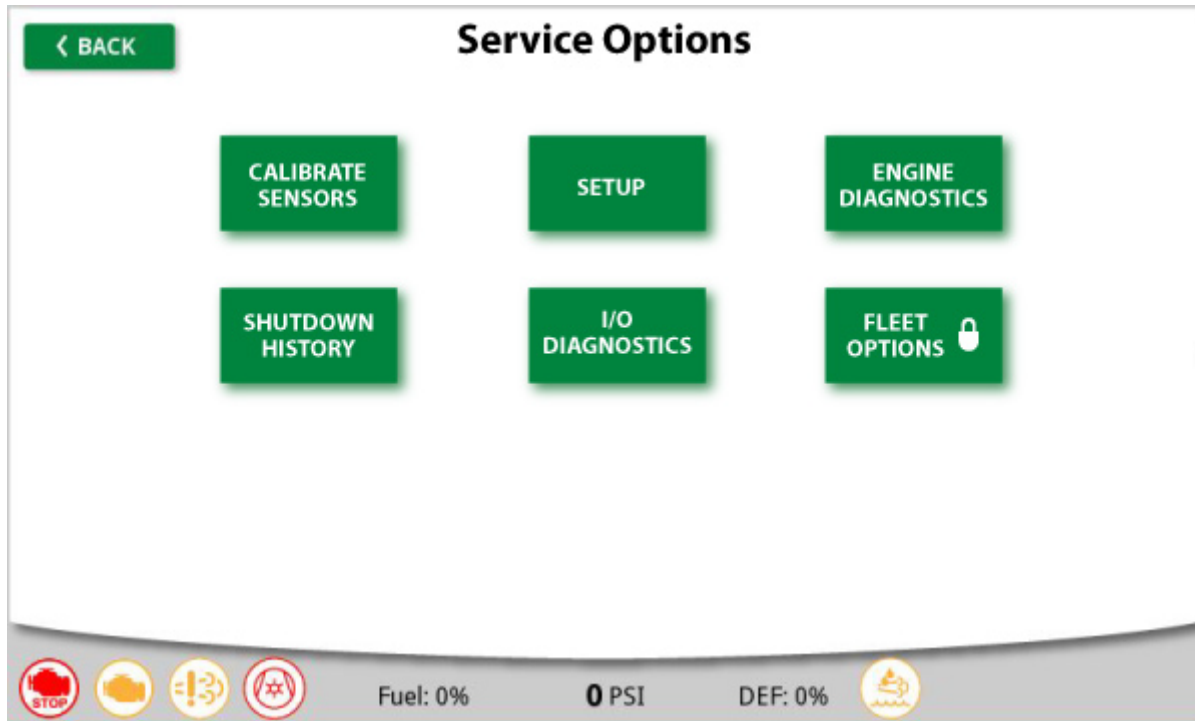

Figure 6-4: Service options layout

Service option sub-menus are accessed via the physical **MENU** button on the front of the controller and the **SERVICE OPTION** soft key.

- **CALIBRATE SENSORS:** This feature is utilized to calibrate machine pressure transducers and temp sensors to known calibrated instrumentation. Sensor calibration is best left to experienced personnel and should not be needed under typical operating conditions.
- **SETUP:** Includes option for enabling/disabling remote start and auto sleep. This menu also includes remote start and auto sleep setting options.
- **ENGINE DIAGNOSTICS:** Displays any active engine codes.
- **SHUTDOWN HISTORY:** A log is provided of all abnormal shutdowns due to any fault conditions. This also includes shutdowns where the emergency stop button was used to stop the machine.
- **I/O DIAGNOSTICS:** Displays state of digital inputs and outputs of the controller as well as analog sensor data to be used as a troubleshooting tool.
- **FLEET OPTIONS:** Includes settings for rental fleet managers to customize available features by job.

6.4.1 Service options: Setup

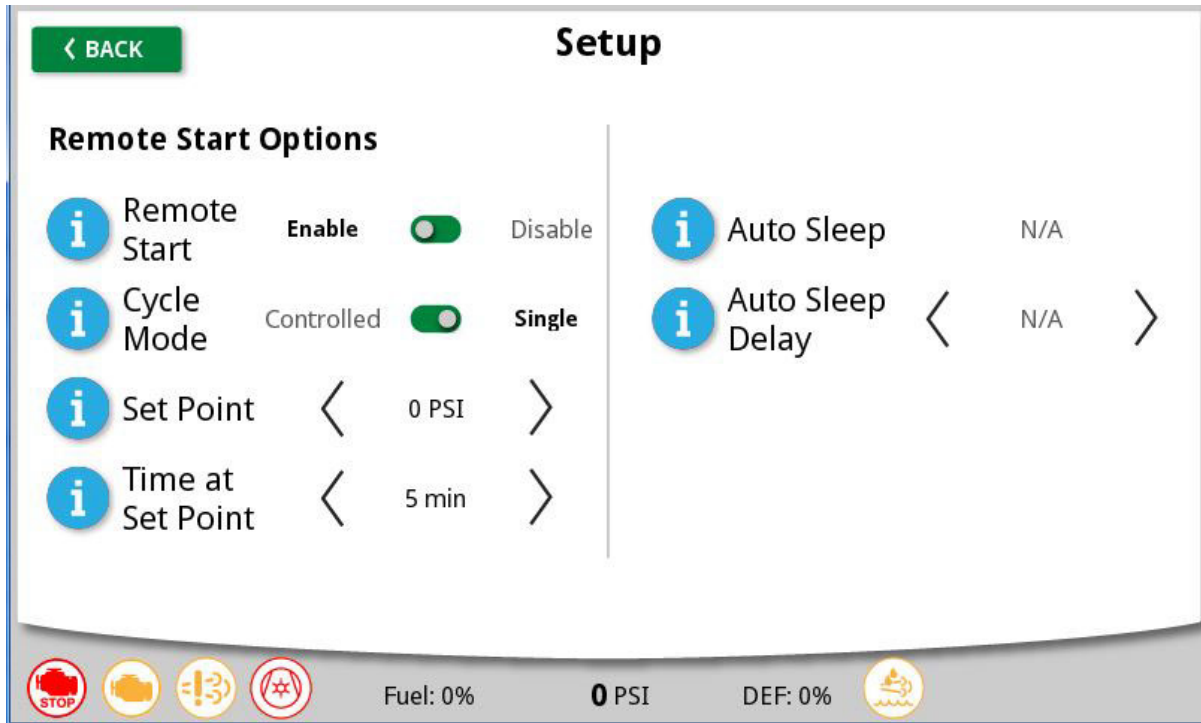

Figure 6-5: Setup options—remote start enabled

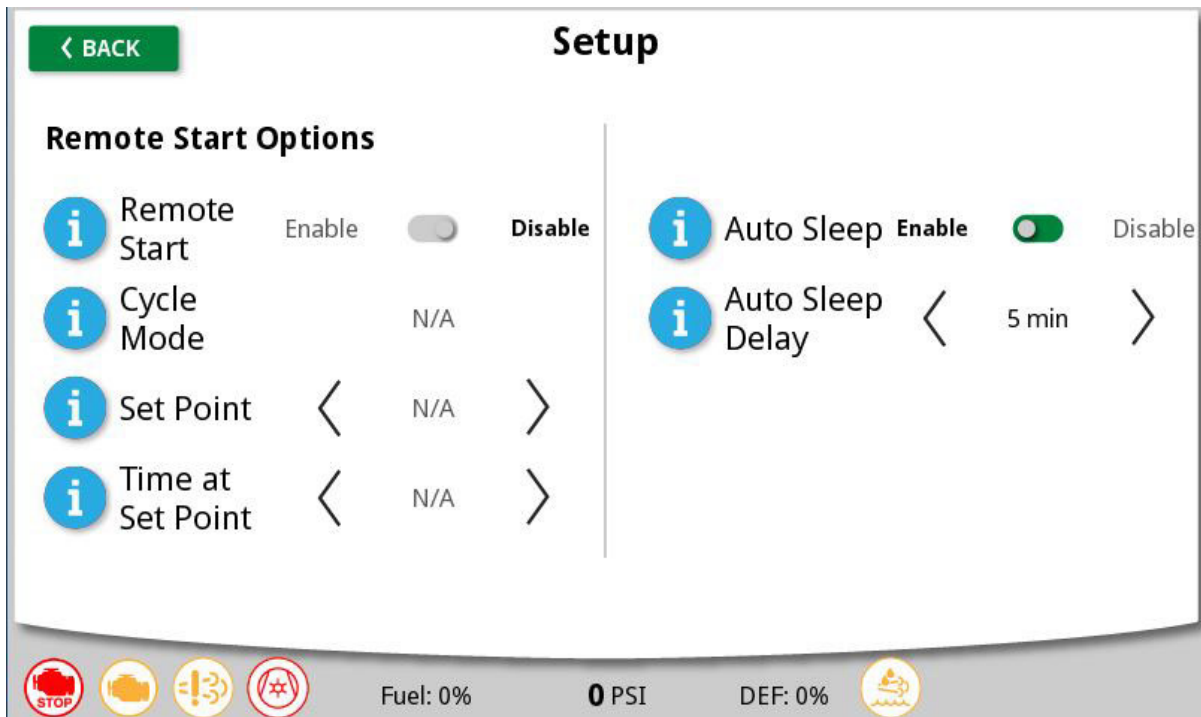



Figure 6-6: Setup options—auto sleep enabled

You can access Setup options by pressing the **SETUP** soft key under the **Service Options** menu. Pressing the  icon next to each setting displays a brief description of that setting. Note that the renter of the equipment can lock out some settings, making them unavailable to the end user.

- **REMOTE START:** When enabled, allows a connection to the remote start input to start the compressor.
- **CYCLE MODE:** Determines how the compressor startup/shutdown cycles are controlled:
 - **Controlled:** When **CYCLE MODE** is set to **Controlled**, the connection to the remote start input controls the compressor's startup/shutdown cycle.
 - **Single:** When **CYCLE MODE** is set to **Single**, the **SET POINT** and **TIME AT SET POINT** settings control the compressor's shutdown cycle. For the compressor to

restart, the remote start input signal must be re-sent.

- **SET POINT:** When the compressor is in Remote Start, Single Cycle mode, **SET POINT** determines the pressure the compressor must reach before the **TIME AT SET POINT** timer begins its countdown.
- **TIME AT SET POINT:** When the compressor is in Remote Start, Single Cycle mode, **TIME AT SET POINT** determines how long the **SET POINT** pressure must be maintained before the compressor will shut down.
- **AUTO SLEEP:** Enables or disables the controller display sleep mode. If enabled, the controller display will shut off after the **AUTO SLEEP DELAY** time has expired. A button or screen press will awaken the display.
- **AUTO SLEEP DELAY:** With **AUTO SLEEP** enabled, this is the delay time that must pass prior to the display shutting off.

6.4.2 Service options: Machine Setup

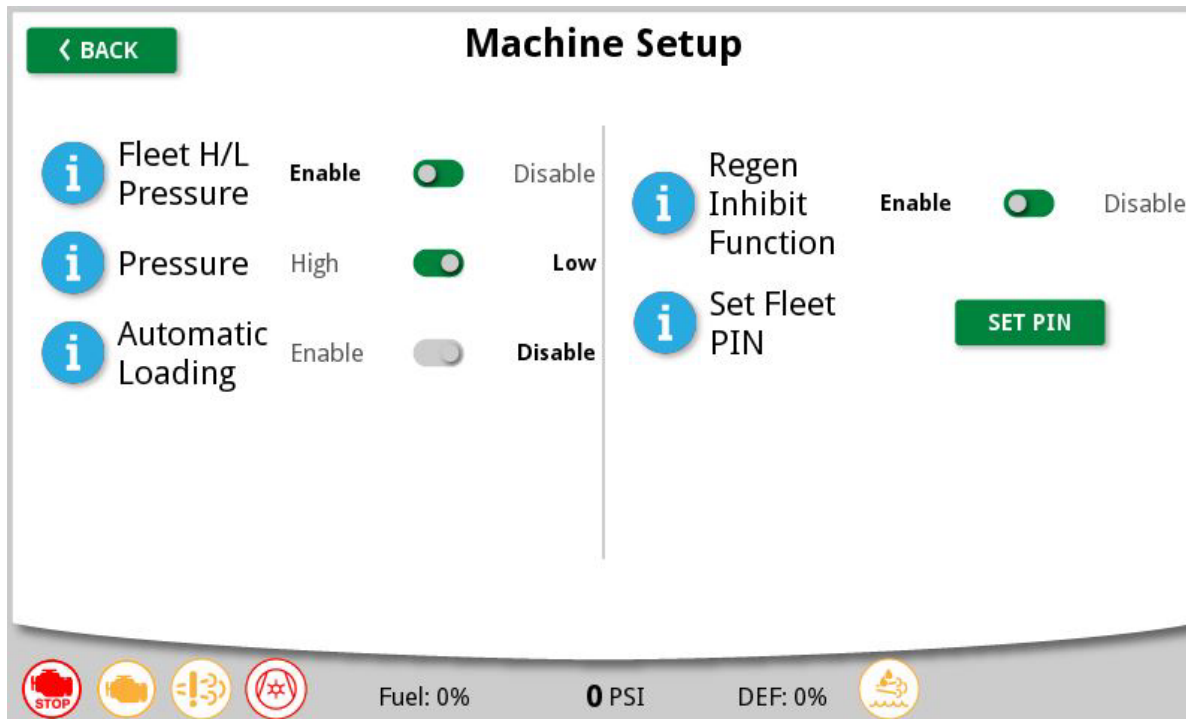

Figure 6-7: Machine Setup options

You can access machine setup options by pressing the **FLEET OPTIONS** soft key under the **Service Options** menu. The fleet manager must enter their password to enter the **Machine Setup** screen.

Pressing the **i** icon next to each setting displays a brief description of that setting. Fleet managers have the ability to customize settings by job.

- **Fleet H/L Pressure:** When set to **Enable**, the end user can select between the **High** or **Low** options of the **Pressure** setting on the **User Options** screen. When set to **Disable**, the end user will not have the ability to toggle between **High** or **Low** options of the **Pressure** setting.
- **Pressure:** When **Fleet H/L** is set to **Enable**, allows the toggle between high or low pressure from the **Machine Setup** to the **User Options** screen.
- **Automatic Loading:** When set to **Disable** (the default setting), the user will need to manually load the machine when text displays “**Ready for Air**” at the bottom-right corner of the screen. When set to **Enable**, the machine will automatically load when transitioning from War-mup mode to Running mode.
 - When enabling **Remote Start** from the **Setup** screen, this feature should be set to **Enable**.
- **Regen Inhibit Function:** When set to **Enable**, the user will have the ability to inhibit the automatic regeneration process from the **User Options** screen. When set to **Disable**, the user will not have the option of inhibiting the regeneration process.
- **Set Fleet PIN:** When pressed, a **Set PIN** screen will display that allows the user to set a password.

6.5 Help



Figure 6-8: Help display

Help menu is accessed via the physical **HELP** button on the front of the controller or the **HELP** soft key in the main menu. This menu contains a QR code which when scanned will take the user to the product manuals. Additionally, there is a soft key for an operational guide and brief troubleshooting section.

6.5.1 Troubleshooting a non-responsive touchscreen

If the touchscreen of the STS Controller stops responding when touched, but is still showing parameters in real time and the operator can still use the five physical buttons below the controller and the **OFF/ON/START** switch, the touchscreen is "frozen" or "locked up" and needs to be reset.

6.5.1.1 Resetting a non-responsive touchscreen

1. Toggle the **OFF/ON/START** switch to the **OFF** position to shut down the compressor.
2. Wait until the engine has stopped running for at least 120 seconds and pressure has dropped to 3 psi.
3. Switch the battery disconnect to the **OFF** position.
 - The battery disconnect is located near the batteries on the upper-right side (see *Figure 2-1* on page 24).
4. Wait 30 seconds.
5. Switch the battery disconnect to the **ON** position.
6. Restart the compressor.

Notes:

Section 7

Maintenance

7.1 General

A good maintenance program is the key to long compressor life. Below is a program that when adhered to, should keep the compressor in top operating condition. For engine maintenance requirements, refer to the *Engine Operator's Manual* for a detailed description of service instructions. Refer to *Section 7.6: Parts replacement and adjustment procedures* on page 64 for a detailed description of specific compressor system components. Prior to performing maintenance, read the *CIMA Safety Manual*, if applicable.

WARNING

Do not remove caps, plugs, and/or other components when compressor is running or pressurized. Stop compressor and relieve all internal pressure before doing so.

7.2 Daily operation and maintenance

Prior to starting the compressor, it is necessary to perform a daily inspection. Perform the following maintenance operations to prevent unnecessary problems.

- Check the fluid level in the compressor receiver tank. Should the level be low, simply add the necessary amount.
- If the addition of fluid becomes too frequent, a simple problem has developed which is causing this excessive loss. Refer to *Table 7-3: Troubleshooting guide* on page 70 under

“Excessive Compressor Fluid Consumption” for a probable cause and remedy.

NOTE

True system oil level can only be determined after the compressor has warmed up to operating temperature and run for a short period of time. This releases trapped oil within the oil cooling system. Short running periods may trap additional oil within the plumbing. Awareness of how the compressor operated and shutdown will help keep the system from being over filled.

- Drain water from the fuel/water separator.
- Check the fuel level in the fuel tank.
- Check the engine oil level.
- Check the engine coolant level.
- Check the DEF level.
- Check for proper tire inflation. Refer to tire sidewall for tire manufacturer’s recommendations.

After a routine start has been made, it is necessary to perform an inspection to ensure all operations are performing correctly. Perform the following inspections to prevent unnecessary problems.

- Observe the instrument panel gauges and be sure they monitor the correct readings for their particular phase of operation.
- After the compressor has warmed up, it is recommended that a general check on the overall compressor and instrument panel be made to assure that the compressor is running properly.
- If equipped, check aftercooler condensate drain system functionality.

7.3 Engine coolant requirements

WARNING

Not following the recommendations of the coolant requirements may induce cooling system inefficiencies which may result in engine overheating. Non-recommended coolant can drastically reduce the life expectancy of the cooling circuit and engine.

This machine is factory filled with Mobil Delvac Extended Life Coolant. It is an ethylene glycol based, OAT inhibited coolant. This coolant is able to protect the cooling system from freezing, extend the boiling point, provide corrosion protection for all metals within the cooling system; especially for systems with aluminum radiators, provide liner cavitation protection for heavy duty diesel engines, and be safe to use with all seals/gasket materials.

This coolant should never be mixed with a different coolant type, color, or brand. If radiator coolant is to be added, for any reason, be sure that the coolant added is the same as what is in the cooling system, as well as what is recommended.

The engine coolant type should follow these recommended specifications:

- Organic acid technology (OAT)
- Premixed coolant pH range of 8.0 to 9.5.
- Contains no silicates, phosphates, borates, nitrates and amines
- Solution states that it is formulated for use in heavy duty diesel applications
- Protects all standard metals within the cooling system (i.e. brass, copper, steel, solder, cast iron, and aluminum.)
- Meets specification requirements of current industry standards which include ASTM D 3306.
- Meets or exceeds performance requirements of current industry standards which include ASTM D 6210.

If you are not sure of the coolant that is installed originally or want to change to a different type, the cooling system must be cleaned with a commercial cleaning agent and then completely flushed and filled with water (preferably distilled) several times to remove all traces of cleaner and old coolant. Finally, fill the system with the recommended coolant using only one brand/type. Cross contamination, which is caused by adding different types of engine coolants, may result in the depletion or dropout of coolant additives; thus leaving cooling system surfaces unprotected against corrosion. Corrosion to radiator surfaces may reduce cooling efficiency and radiator life expectancy. It is extremely important to evacuate/purge all air within the cooling system before replacing the radiator cap. Engine coolant must not only maintain proper freeze protection levels but also maintain proper corrosion inhibitor levels. Please contact the coolant manufacturer for specifics on testing methods and suggested coolant maintenance intervals.

Table 7-1: Coolant service life

Coolant type	Service life
Mobil Delvac EXTENDED LIFE Coolant/Antifreeze	6 years/12,000 hours [†]
[†] Using manufacturer's extender additive to system at 3 years or 6000 hours.	

CAUTION

The radiator and engine cooling system must be drained and flushed periodically. Refer to the *OEM Engine Manual* for more information. Replace the coolant with a solution of 50% ethylene glycol and 50% water or as required for your geographic location. **Do not** use a leak sealing type of antifreeze. Should a 100% water solution be used, a non-chromate rust inhibitor must be added. **Do not** mix coolant types.

NOTE

Dispose of fluids in accordance with applicable federal, state and local regulations.

7.4 Recommended maintenance intervals

7.4.1 Maintenance after initial 50 hours of operation

After the initial 50 hours of operation, a few simple maintenance routines can rid the system of any possible foreign materials, if any. Perform the following maintenance operations to prevent unnecessary problems.

- Clean the receiver tank return line (or scavenge tube) orifice and strainer.
- Change compressor fluid filter
- Inspect and check fan belt tension. If necessary, adjust the tension to 145 ± 10 lbf (645 ± 62 N) while cold.
- Check *Engine Operator's Manual* for required engine service.

7.4.2 Maintenance every 250 hours

- Change fuel system filters.
- Inspect and check fan belt tension. If necessary, adjust the tension to 145 ± 10 lbf (645 ± 62 N) while cold.
- Clean the radiator, oil cooler and aftercooler exterior. Depending on how contaminated the atmosphere may be, more frequent cooler and radiator cleaning may be necessary in dusty conditions.
- Clean the return line orifice and strainer.
- Change compressor fluid filter.

- Check the battery level and fill with water if necessary.
- Check *Engine Operator's Manual* for required engine service.

7.4.3 Maintenance every 500 hours

- Change engine oil and filter.
- Check *Engine Operator's Manual* for required engine service.

7.4.4 Maintenance every 1500 hours

- Change the compressor fluid and replace the fluid filter element.
- Replace separator element. Depending on operating environment, replacement could be required earlier. In this case, it will be indicated by the controller.
- (If equipped) Replace the discharge air filter elements.
- Concerning compressor models with running gear and brakes:
 - Depending on the compressor's working environment and the amount of travel it encounters, the braking system may require more frequent adjustment which is left to the discretion of the end-user. See *Section 7.6.7* through *Section 7.6.10*.
- Check *Engine Operator's Manual* for required engine service.

SVS	Consumable Desc.	Qty	Part number	Kit inclusion						
				50	250	500	750	1000	1250	1500
Compressor	Air Filter - Primary	1	02250155-691	*	*	X	*	X	*	X
	Air Filter - Secondary/Safety	1	02250155-692	*	*	*	*	*	*	X
	Oil Filter	1	02550139-996	X	X	X	X	X	X	X
	Separator Element	1	02250225-756							X
	Fluid - Oil	6	250030-757							X
Engine	Air Filter - Primary	1	02250155-691	*	*	X	*	X	*	X
	Air Filter - Secondary/Safety	1	02250155-692	*	*	*	*	*	*	X
	Oil Filter	1	02250245-921			X		X		X
	Fuel Filter - Primary	1	02250245-919			X		X		X
	Fuel Filter - Secondary	2	02250245-920			X		X		X

* If equipped, replace air filter if restriction indicator shows that filter needs changed. Depending on operating environment, filter may need to be changed prior to maintenance interval.

7.5 Engine maintenance

Check *Engine Operator's Manual* for required engine service.

7.6 Parts replacement and adjustment procedures

7.6.1 Compressor fluid change procedure

Warm-up the compressor for 5 to 10 minutes to warm the fluid. Shut the compressor off and relieve all internal pressure before proceeding. Drain the fluid by opening the valves that are bulkhead mounted to the frame (see ID drawing under *Section 2.12* on page 36 for location of drain port). Change the compressor fluid and replace the fluid filter element. For element replacement see procedure for servicing the fluid filter in this section. Fill the receiver tank with fluid according to *Section 7.6.2: Main fluid filter servicing*.

7.6.2 Main fluid filter servicing

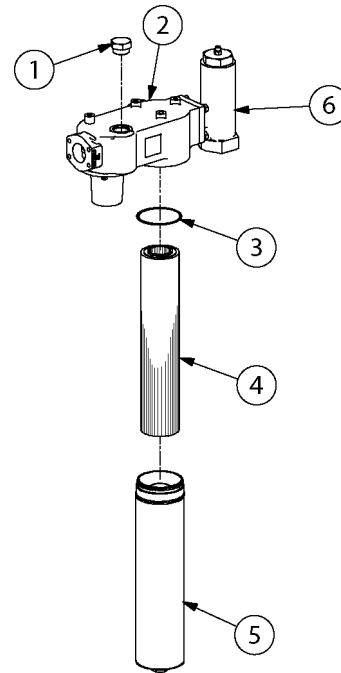

- | | |
|------------------------|---------------------|
| 1. Fluid filter bypass | 4. Element |
| 2. Filter head | 5. Bowl |
| 3. Bowl seal (O-ring) | 6. Fluid stop valve |

Figure 7-1: Main fluid filter assembly

Refer to *Figure 7-1*. The main fluid filter is located schematically in the coolant line between the receiver tank and the compressor unit. The main filter element is replaceable. For installation of the filter element, follow the procedure explained below.

1. The compressor **must** be shut off and system pressure **must** be relieved.
2. Drain by removing drain plug at bottom of bowl and catching drainage in a container.
3. Rotate bowl counterclockwise and remove.
4. Remove element and O-ring from housing and discard (this element is **not** cleanable).
5. Make sure mounting surface of filter head is clean.
6. Apply a light film of compressor oil to O-ring and place it in its proper position.
7. Place new, clean element in bowl, over center-perforated tub.

8. Inspect bowl seal and replace if necessary.
9. Replace bowl. Rotate clockwise and hand-tighten.
10. Replace drain plug. Torque to 15 to 20 lbf ft. (20 to 27 N m).

7.6.3 Air filter maintenance

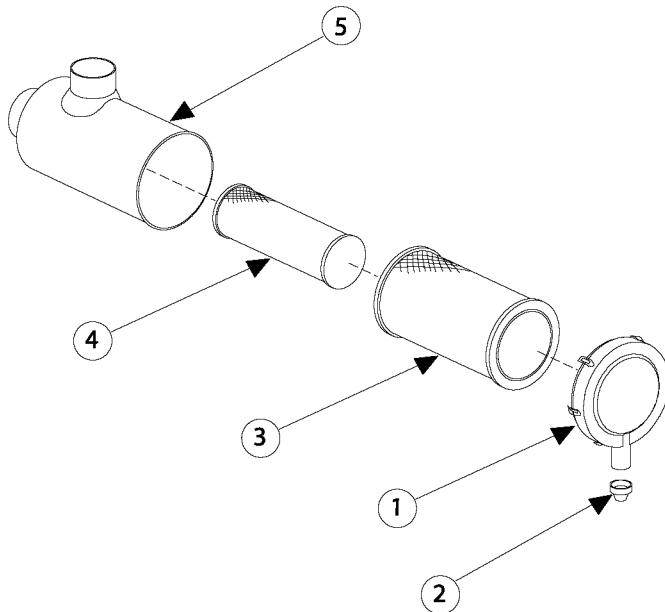

- | | |
|---------------------|------------------------|
| 1. Access cover | 4. Secondary element‡ |
| 2. Vacuator™ valve | 5. Air cleaner housing |
| 3. Primary element† | |

†Primary replacement element, P/N 02250155-691 (qty 2)

‡Secondary replacement element, P/N 02250155-692 (qty 2)

Figure 7-2: Air filter assembly

Refer to *Figure 7-2*. Maintenance should be performed when indicated by the controller. Both air filters are two-stage with a primary element and secondary element each.

7.6.3.1 Primary element removal

1. Clean the exterior of the air filter housing.
2. Unlatch and remove the service cover. Make certain the latches are folded back.

3. Remove the primary filter from the housing.
4. Clean the interior of the housing by using a damp cloth. **Do not** blow out dirt with compressed air as this may introduce dust downstream of the filter.

7.6.3.2 Secondary element removal

The secondary element serves as a safety element. The secondary element must be replaced after every third primary element change.

1. Gently pull the element off the outlet tube and out of the housing.
2. Carefully wipe the inside of the outlet tube with a clean cloth.

7.6.4 Control system adjustment

Refer to *Figure 7-3*. Prior to adjusting the control system, it is necessary to determine the desired operating pressure range as well as the maximum pressure at which the machine is to operate. This pressure is stamped on the machine serial number plate.

Follow the procedure below for setting up the pressure regulator.

1. Start the machine and let it warm-up and press the **LOAD** button.
2. Open service valve slightly until engine tries to speed up, then slowly close the service valve.
3. With service valve closed and the engine at low idle (1400 rpm), adjust the pressure regulator until the service pressure is approximately 20 – 25 psi (1.4 – 1.7 bar) above the desired operating pressure.

- For example, if the desired service pressure is 150 psig (10.3 bar), the regulator should be adjusted to 170 – 175 psig (11.7 – 12.1 bar) at 1400 rpm. Open the service valve to load the compressor to maintain 150 psig (10.3 bar) or desired discharge pressure. Operating speed should be 1800 rpm on the instrument panel. If not, repeat step, but adjust the unload service pressure up or down as needed until 150 psig (10.3 bar) is maintained when engine speed is 1800 rpm.

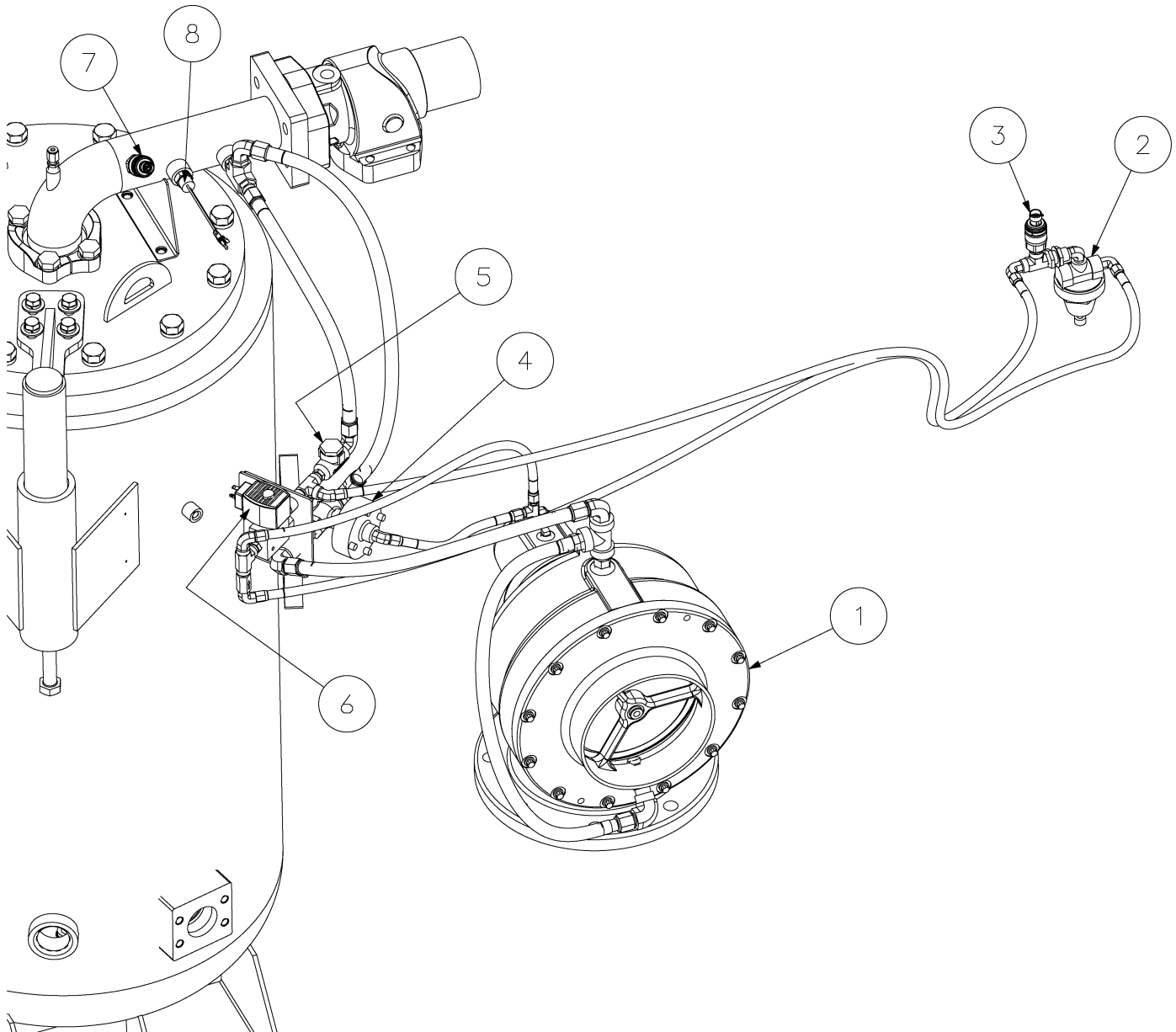

- | | |
|--------------------------------|---------------------------------|
| 1. Compressor inlet valve | 5. Strainer |
| 2. Pressure regulator | 6. Start/run solenoid valve |
| 3. Control pressure transducer | 7. System pressure transducer |
| 4. Blowdown valve | 8. Discharge temperature switch |

Figure 7-3: Pneumatic control system

7.6.5 Separator element replacement

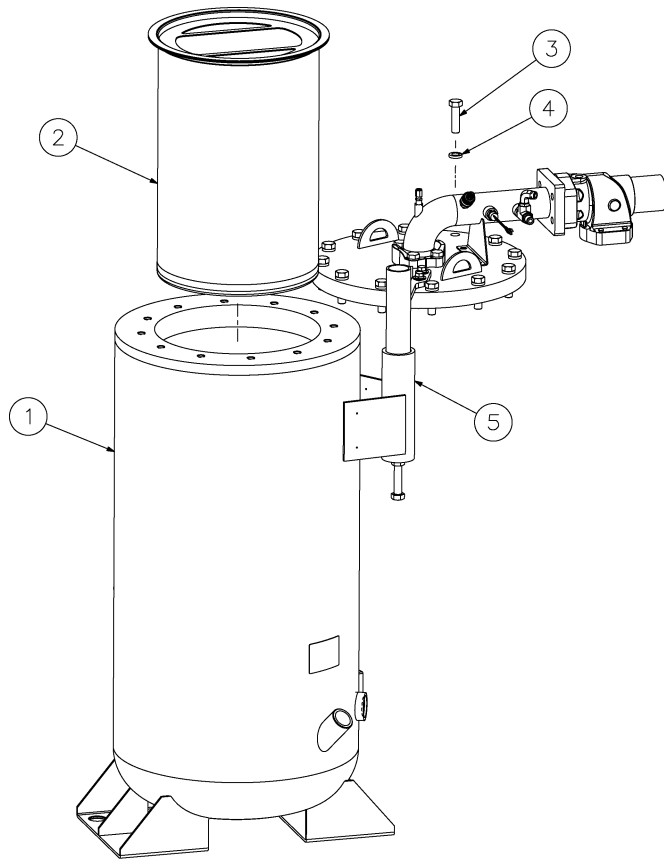

1. Receiver tank
2. Separator element
3. Capscrew
4. Spring lock washer
5. Lid davit support

Figure 7-4: Separator element assembly

Refer to *Figure 7-4*. Use the following procedure for separator replacement.

1. Remove the air receiver tank lid by removing the hex head capscrews and washers.

CAUTION

To assist with the removal of the tank lid, Sullair has provided a jack bolt at the bottom of the lid pivot shaft. Simply jack the lid up and rotate out of the way.

2. Remove the element from the tank. An access panel in the roof is provided and the element is equipped with lifting provisions.
3. Scrape the old gasket material from the tank flange and lid of tank. **Do not** allow gasket material to fall into separator tank.
4. Reinsert new element with gaskets attached. Take care not to damage the element against the side of the tank.
 - **Do not** remove grounding staples.
 - **Do not** use anti-seize compound on gaskets.
5. Install, lubricate and torque bolts to 200 lbf ft (271 N m).
 - Perform a continuity check between element flange and tank body and lid after torquing bolts.
6. Reconnect all piping making sure the return line tube is ¼" above the bottom of the separator element.
7. Clean or replace fluid return line strainer and return line orifice.

7.6.6 Running gear—brake shoe maintenance and adjustment

WARNING

Before proceeding, park or locate the compressor on flat stable ground. Block or chock both sides of all wheels. Use proper personal protection equipment when performing these tasks described below.

The electric brakes have a self-adjusting feature. Should manual adjusting be needed, use the following procedure:

1. Jack up compressor and secure on adequate capacity jack stands. Make sure the wheel and drum rotates freely.

2. If equipped, remove the adjusting hole cover from the adjusting slot on the bottom of the brake backing plate.
3. With a screwdriver or standard adjusting tool, rotate the star wheel of the adjuster assembly to expand the brake shoes. Adjust the brake shoes out until the pressure of the linings against the drum makes the wheel very difficult to turn.
4. Then rotate the star wheel in the opposite direction until the wheel turns freely with a slight lining drag.
5. Replace the adjusting hole cover and lower the wheel to the ground.
6. Repeat the above procedure on all brakes. For best results, the brakes should all be set at the same clearance.

7.6.7 Brake cleaning and inspection

WARNING

Before proceeding, park or locate the compressor on flat stable ground. Block or chock both sides of all wheels. Use proper personal protection equipment when performing these tasks described below.

Your brake system must be inspected and serviced immediately if a loss of performance is indicated. With normal use, servicing at one year intervals is usually adequate. With increased usage, maintenance should be performed more frequently as required. Magnets and shoes must be changed when they become excessively worn or scored, a condition which can reduce vehicle braking.

Clean the backing plate, magnet arm, magnet, and brake shoes. Make certain that all the parts removed are replaced in the same brake and drum assembly. Inspect

for any loose or worn parts, stretched or deformed springs and replace as necessary.

CAUTION

Potential asbestos dust hazard

Some older brake linings may contain asbestos dust, which has been linked to serious or fatal illnesses. Certain precautions need to be taken when servicing brakes:

- Avoid creating or breathing dust.
- Avoid machining, filing or grinding the brake linings.
- Do not use compressed air or dry brushing for cleaning (dust can be removed with a damp brush).

7.6.8 Brake lubrication

Before reassembling, apply a light film of grease or anti-seize compound on the brake anchor pin, the actuation arm bushing and pin, and the areas on the backing plate that are in contact with the brake shoes and magnet lever arm. Apply a light film of grease on the actuating block mounted on the actuating arm.

CAUTION

Do not get grease or oil on the brake linings, drums or magnets.

7.6.9 Bearing lubrication—grease

CAUTION

Do not mix lithium, calcium, sodium or barium complex greases due to possible compatibility problems. When changing from one type of grease to another, it is necessary to ensure all the old grease has been removed.

Grease should be replaced every 12,000 miles or 12 months. Prior to repacking bearings, all old grease should be removed from the wheel hub cavity and bearings. Bearings should be packed by a packing machine, if possible. If a packing machine is unavailable, packing by the hand method is acceptable. The method to pack bearing cones is as follows:

1. Place a quantity of grease onto the palm of your hand.

2. Press a section of the widest end of the bearing into the outer edge of the grease pile closest to the thumb forcing grease into the interior of the bearing between two adjacent rollers.
3. Repeat this while rotating the bearing from roller to roller.
4. Continue this process until you have the entire bearing completely filled with grease.
5. Before reinstalling, apply a light coat of grease onto the bearing cup mating surface.

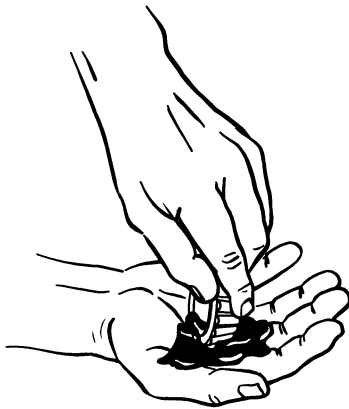

Figure 7-5: Packing a bearing

Table 7-2: Wheel bearing lubrication, grease—specifications†

Specification	Requirements
Thickener Type	Lithium Complex
Dropping Point	215°C (419°F) Minimum
Consistency	NLGI No.2
Additives	EP, Corrosion & Oxidation Inhibitors
Viscosity	80 Minimum
†Source: Dexter Axle Company 9,000 – 15,000 Lbs. Capacity Operation Maintenance Service Manual	

7.6.10 Axle bearing adjustment

1. Install the bearing and washer into the hub. Thread on the inner nut, rotate the hub and tighten the nut to 100 lbf ft (136 N m) of torque.
2. Loosen the nut to remove the pre-load torque. **Do not rotate the hub.**
3. Hand tighten the nut, then back it off ¼ to ⅜ turn.
4. Place the tang washer on the spindle and bend two tangs inward over the nut. This will keep the inner nut from turning while torque is applied to the outer nut.
5. Install the outer nut and torque it to 150 – 175 lbf ft (136 – 233 N m). Insure that the inner nut does not turn. Bend two tangs from the tang washer over the outer nut flats to secure.
6. Install cap with the O-ring and plug installed. Rotate the hub and check the bearing adjustment. The allowable end play is .001" – .010".

CAUTION

Failure to back off the inner adjusting nut could cause bearing and axle spindle overheating or damage, which could result in the wheel locking up or coming off during vehicle operation and lead to an accident, injuries or death.

CAUTION

Failure to torque the outer locknut properly could cause the wheel end to come off during operation which could result in an accident, injuries or death.

7.7 Troubleshooting

Table 7-3 is based on both the data obtained from actual tests conducted at our factory and real applied situations. It contains symptoms and usual causes for the described problems. However, **do not** assume that these are the only problems that may occur. All available data concerning the trouble should be systematically analyzed before undertaking any repairs or component replacement procedures.

- Check for loose wiring.

- Check for damaged piping.
- Check for parts damaged by heat or an electrical short circuit, usually apparent by discoloration or a burnt odor.

Should your problem persist after making the recommended check, consult your nearest Sullair representative or Sullair.

Table 7-3: Troubleshooting guide

Symptom	Probable cause	Remedy	
Compressor will not start	No fuel	Check fuel level and add fuel if necessary.	
	Plugged fuel filter	Replace the fuel filter element(s).	
	Battery		Check electrolyte level and add distilled water and recharge if necessary.
			Loose battery cables; tighten cables. Dirty battery cables; clean thoroughly.
	Plugged air filter	Replace the air filter element.	
	Engine problems may have developed	Check active engine codes and refer to <i>Engine Operator's Manual</i> .	
Electrical control fault	Refer to the controller message bar for details.		
Compressor shuts down with air demand present	No fuel	Check fuel gauge and add fuel if necessary.	
	Compressor discharge temperature switch is open		Cooling air flow is insufficient; clean cooler and check for proper ventilation.
			Low fluid sump level; add fluid.
			Dirty compressor fluid filter; change element.
		Thermostatic element is not functioning properly; change the thermostatic element.	
		Defective discharge temperature switch; check for a short or open circuit to the engine fuel solenoid. Should this check out normal, it could be possible that the temperature switch itself is defective.	
	Electrical control fault	Refer to the controller message bar for details.	
Low DEF level	Check DEF level gauge and add if necessary.		
Exhaust aftertreatment fault	Check active engine codes and refer to <i>Engine Operator's Manual</i> .		

Table 7-3: Troubleshooting guide

Symptom	Probable cause	Remedy
Compressor will not build up full discharge pressure	Air demand is too great	Check service lines for leaks of open valves.
	Service valve fully open	Set service valve to achieve desired service pressure.
	Dirty air filter	Check the controller for service recommendation.
	Pressure regulator out of adjustment	Adjust regulator according to control adjustment instructions in the <i>Section 7.6.4</i> .
	Defective pressure regulator	Check diaphragm and replace if necessary (kit available).
	Defective air inlet valve	Replace inlet valve.
	Engine is in de-rate due to fault condition	Check active engine codes and refer to <i>Engine Operator's Manual</i> .
Improper unloading with an excessive pressure build-up causing pressure relief valve to open	Fluid charge lost from spring chamber on inlet valve	Add fluid to inlet valve spring chamber by removing plugs in the top of the spring chamber and filling with compressor fluid.
	Pressure regulator valve set too high or defective	Adjust or repair.
	Leak in control system causing loss of pressure signal	Check control lines. Worn seals in inlet valve. Replace seals (kit available).
	Restriction in the control system	Check all control lines and components. Ice and other contaminants could cause restrictions.
	Defective pressure relief valve	Replace pressure relief valve.
Insufficient air delivery	Plugged air filter	Replace.
	Plugged air/fluid separator	Replace separator element and also change compressor fluid and fluid filter at this time.
	Defective or incorrectly set pressure regulator	Adjust or repair.
	Leaks in discharge system or service hoses/lines.	Check for leaks and repair.
	Engine is in de-rate due to fault condition	Check active engine codes and refer to <i>Engine Operator's Manual</i> .

Table 7-3: Troubleshooting guide

Symptom	Probable cause	Remedy
Excessive compressor fluid consumption	Clogged return line	Clean orifice and strainer.
	Leak in the lubrication system	Check all pipes, connections and components
	Separator element damaged or not functioning properly	Change separator element.
	Defective minimum pressure/check valve	Repair or replace.
	Fluid receiver tank overfilled	Drain to proper level.
	Low operating service pressure	Adjust service valve to maintain desired service pressure.
Compressor overheating	Loose or broken fan belt	Tighten or change belt
	Dirty fluid cooler core	Clean core thoroughly.
	Faulty thermostat element	Change thermostat element.
	Low receiver tank fluid level	Refill.
	Plugged compressor fluid filter	Change element.
Engine overheating	Loose or broken fan belt	Tighten or change belt.
	Dirty radiator core	Clean thoroughly.
	Low water level	Refill.
	Plugged radiator	Clean and flush thoroughly.
	Defective engine thermostat	Replace engine thermostat.

Section 8

Noise Control

8.1 Noise emissions warranty

Sullair warrants to the ultimate purchaser and each subsequent purchaser that this air compressor was designed, built and equipped to follow at the time of sale to the first retail purchaser, with all applicable U.S. E.P.A. and/or any Federal, State or Local noise control regulations.

This warranty is not limited to any particular part, component, or system of the air compressor. Defects in the design, assembly, or in any part, component, or system of the compressor which, at the time of sale to the first retail purchaser, caused noise emissions to exceed Federal standards are covered by this warranty for the life of the air compressor.

8.2 Tampering with the noise control system is prohibited

Federal Law prohibits the following acts or the causing thereof:

1. The removal or rendering inoperative by any persons, other than for purposes of maintenance, repair, or replacement, of any device or element of design incorporated into any new compressor for the purpose of noise

control prior to its sale or delivery to the ultimate purchaser or while it is in use.

2. The use of the compressor after such device or element of design has been removed or rendered inoperative by any person.

Among those acts included in the prohibition against tampering are the acts listed below:

1. Removal or rendering inoperative any of the following:
 - Engine exhaust system or parts thereof
 - Compressor air intake system or part thereof
 - Enclosure of part thereof
2. Removal of any of the following:
 - Vibration isolators
 - Control silencer
 - Floor panel
 - Fan shroud
 - Acoustical materials
3. Operation with canopy doors open for any purpose other than starting, stopping, adjustment, repair, replacement of parts or maintenance.

8.3 Noise emissions maintenance and maintenance record log

The following instructions and maintenance record log book, for the proper maintenance, use and repair of this compressor, is intended to prevent noise emission degradation.

Table 8-1: Annual muffler and exhaust system inspection

At least annually inspect muffler(s) and engine exhaust system to make sure all parts are securely mounted, that all joints and connections are tight, and that the muffler is in good condition. **Do not** operate compressor with defective exhaust system. Remove and replace any defective parts by ordering with part numbers indicated in the Parts List.

Maintenance performed:

By:

Location:

Date:

Maintenance performed:

By:

Location:

Date:

Maintenance performed:

By:

Location:

Date:

Table 8-2: Annual air filter(s) and air inlet system inspection

In addition to the instructions in the Maintenance section of the Operator's Manual, the air filter(s) and entire air inlet system should be inspected at least annually, to make sure all parts are securely mounted, that all joints and connections are tight, that there are no other leaks in the system, and that the filter element(s) are intact. **Do not** operate compressor with defective air inlet system. Remove and replace defective parts by ordering with part numbers indicated in the Parts List.

Maintenance performed:

By:

Location:

Date:

Maintenance performed:

By:

Location:

Date:

Maintenance performed:

By:

Location:

Date:

Table 8-3: Annual engine vibration mount inspection

At least annually inspect engine vibration mounts for security of attachment and to make sure the resilient parts are intact. **Do not** operate compressor with defective engine mounting system. Remove and replace defective parts by ordering with part numbers indicated in Parts List.

Maintenance performed:

By:

Location:

Date:

Maintenance performed:

By:

Location:

Date:

Maintenance performed:

By:

Location:

Date:

Table 8-4: Annual frame, canopy and parts inspection

At least annually inspect frame, canopy and parts, for security of attachment. Make sure there are not any missing or deformed members, including all hinged doors, covers and their fastening devices. **Do not** operate compressor with defective frame, canopy and parts. Remove and replace defective parts by ordering with part numbers indicated in Parts List.

Maintenance performed:

By:

Location:

Date:

Maintenance performed:

By:

Location:

Date:

Maintenance performed:

By:

Location:

Date:

Table 8-5: Annual acoustical materials inspection

At least annually inspect all acoustical materials, if any, for security of attachment. Make sure that there is not any material missing or damaged (refer to Parts List). Clean or replace, if necessary. **Do not** operate compressor with defective acoustical material. Remove and replace defective parts by ordering with part numbers indicated in the Parts List.

Maintenance performed:

By:

Location:

Date:

Maintenance performed:

By:

Location:

Date:

Maintenance performed:

By:

Location:

Date:

Table 8-6: Annual inspections for proper operation of all systems

In addition to other instructions in the Operator’s Manual, at least annually, operate compressor and inspect to make sure all systems are operating properly and that engine runs at rated speed and pressure. **Do not** operate malfunctioning or improperly adjusted compressor. Repair or adjust, per instructions in Operator’s Manual, as required.

Maintenance performed:

By:

Location:

Date:

Maintenance performed:

By:

Location:

Date:

Maintenance performed:

By:

Location:

Date:

Appendix A: Acronyms and Abbreviations

CEM—Clean Emissions Module

DEF—Diesel Exhaust Fluid

DOC—Diesel Oxidation Catalyst

DPF—Diesel Particulate Filter

ECU—Engine Control Unit

NO_x—Oxides of Nitrous (NO and NO₂)

PETU—Pump Electronic Tank Unit

SCR—Selective Catalytic Reduction

Notes:

WARNING

Breathing diesel engine exhaust exposes you to chemicals known to the State of California to cause cancer and birth defects or other reproductive harm.

- Always start and operate the engine in a well-ventilated area.
- If in an enclosed area, vent the exhaust to the outside.
- Do not modify or tamper with the exhaust system.
- Do not idle the engine except as necessary.

For more information go to www.P65warnings.ca.gov/diesel



Sullair, LLC

1 Sullair Way
Michigan City, IN 46360 USA

www.sullair.com

1-800-SULLAIR (USA only)

1-219-879-5451 (non-USA)